

X30 WATERSWIFT 60CC - TAG

		FEATURES - CARACTERISTIQUES	
		Cylinder volume <i>Volume du cylindre</i>	59.17 cm ³ (60.00 cm ³ max)
		Bore <i>Alésage</i>	41.81 mm
		Max. bore <i>Alésage max.</i>	42.10 mm
		Max. Stroke <i>Course max.</i>	43.15 mm
		Cooling system <i>Système de refroidissement</i>	Water <i>Eau</i>
		Inlet system <i>Système d'admission</i>	Piston valve <i>Jupe de piston</i>
		Number of carbs <i>Nombre de carburateurs</i>	1
Tillotson Carburettor <i>Carburateur Tillotson</i>	HW-31A (Venturi Ø17)	Cylinder / crankcase transfers n° <i>N° de canaux cylindre / carter</i>	2
Number of piston rings <i>Nombre de segments</i>	1	Inlet / exhaust ports number <i>N° lumières admiss / échapp.</i>	1 / 1
Big end conrod bearing diam. <i>Diamètre palier tête de bielle</i>	18x24x15	Combustion chamber shape <i>Forme chambre de combustion</i>	Spherical <i>Sphérique</i>
Crankshaft ball-bearing diam. <i>Diamètre palier du vilebrequin</i>	20x47x14	Selettra ignition (adjustable) <i>Allumage Selettra (réglable)</i>	2 poles 2 pôles
Small end conr. bearing diam. <i>Diamètre palier pied de bielle</i>	12x16x16	Distance between Conrod centres <i>Longueur (entre axe) de la bielle</i>	88 mm

DESCRIPTION OF THE MATERIAL DESCRIPTION DES MATERIAUX		PISTON
Conrod material <i>Matériel de la bielle</i>	Steel <i>Acier</i>	 <p>Min. Weight Piston included ring = 60 g Poids Min. Piston avec segment = 60 g</p>
Crankshaft material <i>Matériel du vilebrequin</i>	Steel <i>Acier</i>	
Head Material <i>Matériel de la culasse</i>	Aluminium	
Cylinder Material <i>Matériel du cylindre</i>	Aluminium	
Liner material <i>Matériel de la chemise</i>	Cast Iron <i>Fonte</i>	DISTANCE BETWEEN CONROD CENTERS ENTRE AXE DE LA BIELLE
Crankcase material <i>Matériel du carter</i>	Aluminium	 <p>Min. Weight 80 g Poids min.</p>
Piston material <i>Matériel du piston</i>	Aluminium	
Piston rings material <i>Matériel des segments</i>	Cast Iron <i>Fonte</i>	
Exhaust muffler material <i>Matériel du pot d'échappement</i>	Sheet-steel <i>Tôle acier</i>	
Ball-bearings <i>Roulements</i>	6204 type	

CRANKSHAFT - VILEBREQUIN

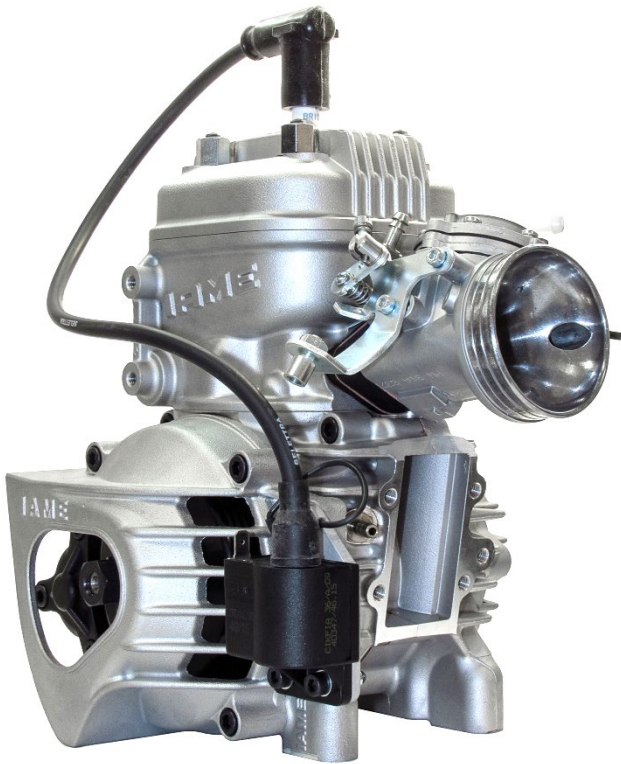
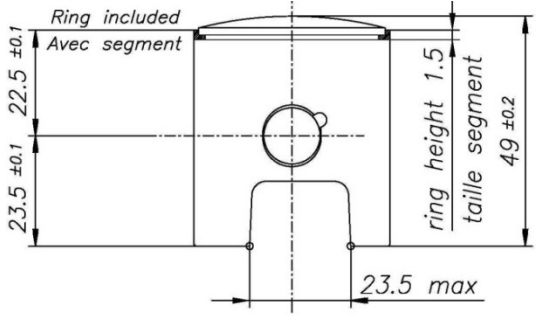
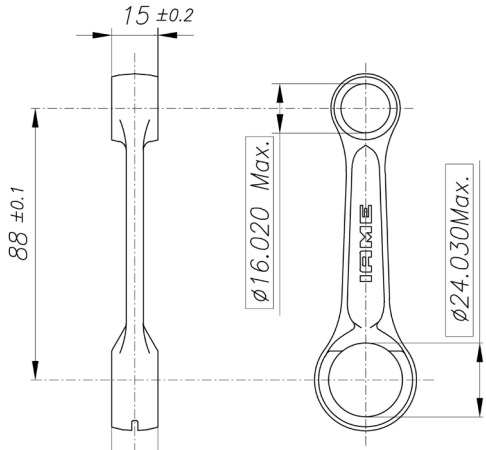
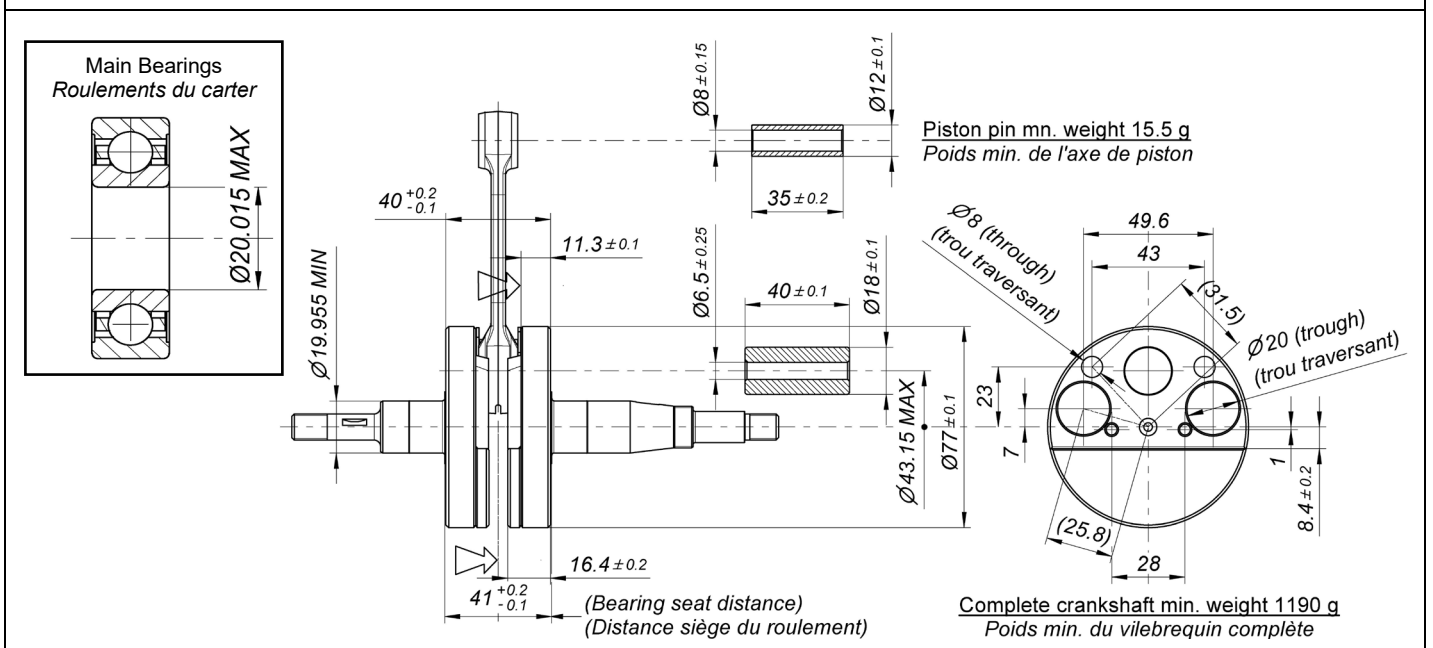

CYLINDER DEVELOPMENT – DEVELOPPEMENT DU CYLINDRE

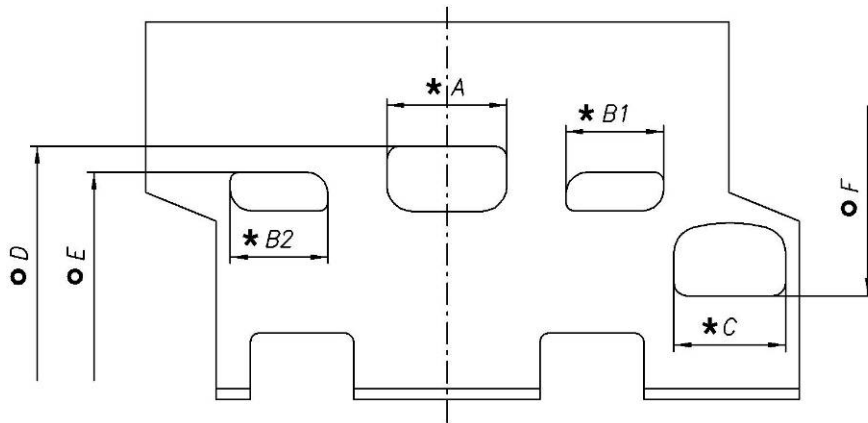

A	28±0.2 mm
B1 = B2	21.8±0.2 mm
C	26±0.2 mm
D	157° max
E	116° ±2°
F	145° max

CHORDAL READING – LECTURE CORDALE

ANGULAR READING BY INSERT A 0.2 mm x 5 mm GAUGE –
LECTURE ANGULAIRE PAR INSERTION D'UNE CALE DE 0.2 mm x 5 mm

USING IAME TOOL Cod. 10194 – *UTILISER OUTIL*

CYLINDER BASE VIEW
VUE DE LA BASE DU CYLINDRE

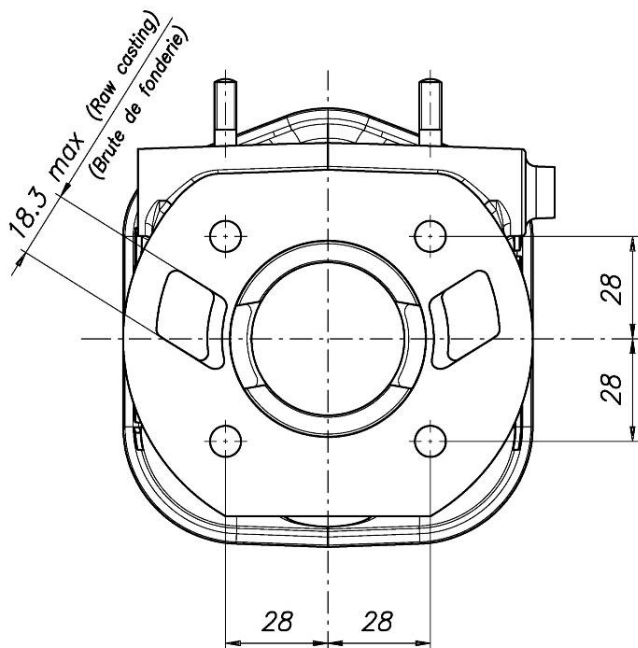

CYLINDER SECTION VIEW
VUE EN SECTION DU CYLINDRE

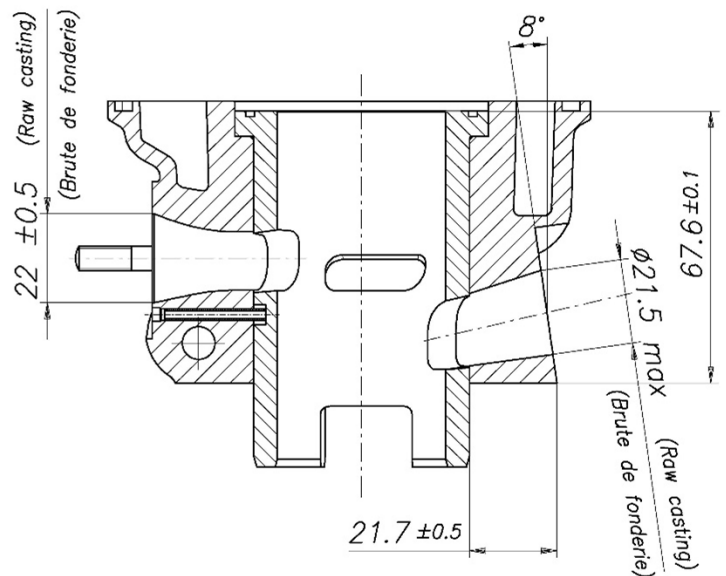

COMBUSTION CHAMBER VIEW
VUE DE LA CHAMBRE DE COMBUSTION

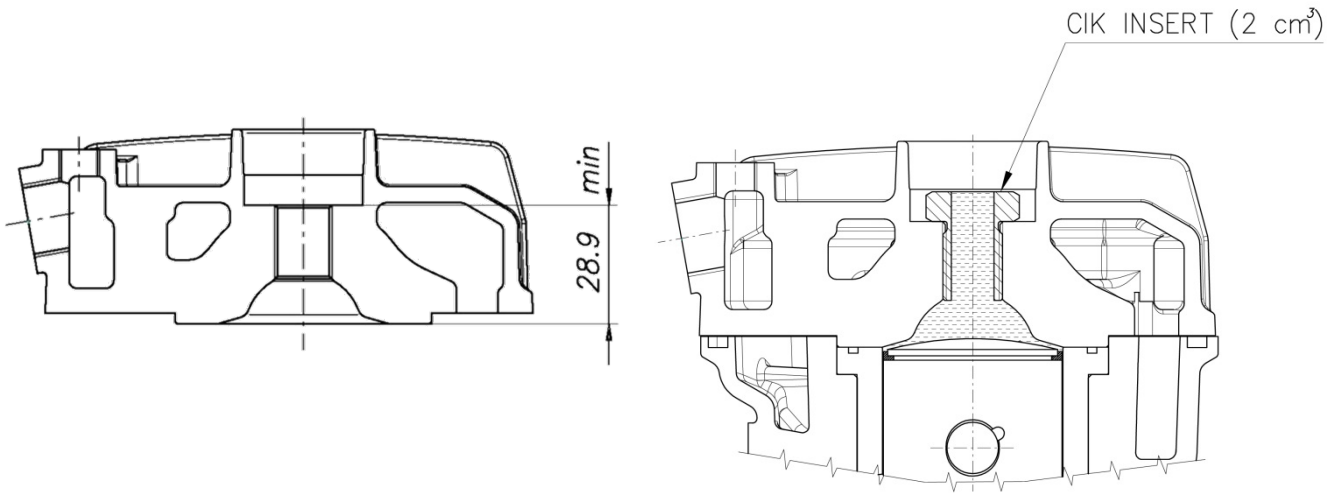

COMBUSTION CHAMBER VOLUME = 6.5 cm³ min.
VOLUME CHAMBRE COMBUSTION

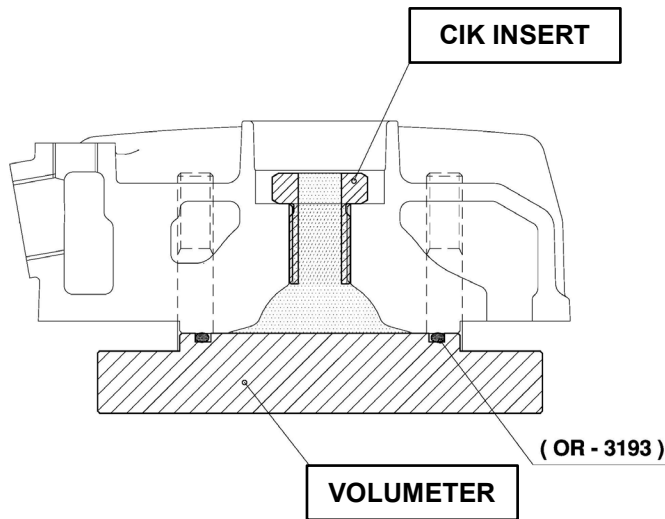

SQUISH MIN. = 0.75 mm
measured with Ø1.5mm TIN
mesurée avec de l'étain Ø1.5mm

MIN. TOT. VOLUME OF CHAMBER IN THE CYLINDER HEAD = 7.4 cm³
VOLUME MIN. CHAMBRE DE COMBUSTION DANS LA CULASSE

REAR VIEW AND DIMENSION
ARRIERE VUE ET DIMENSION

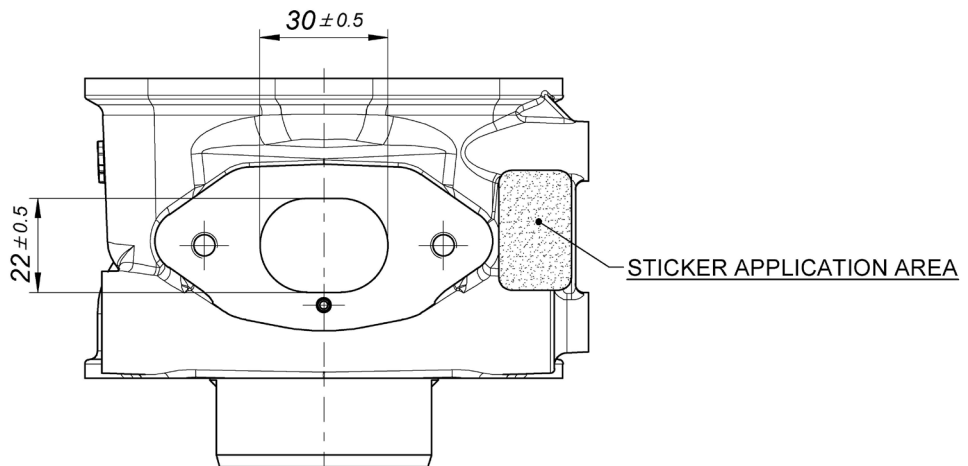

**CRANKCASE INSIDE VIEW
VUE A L'INTERIEUR DU CARTER**

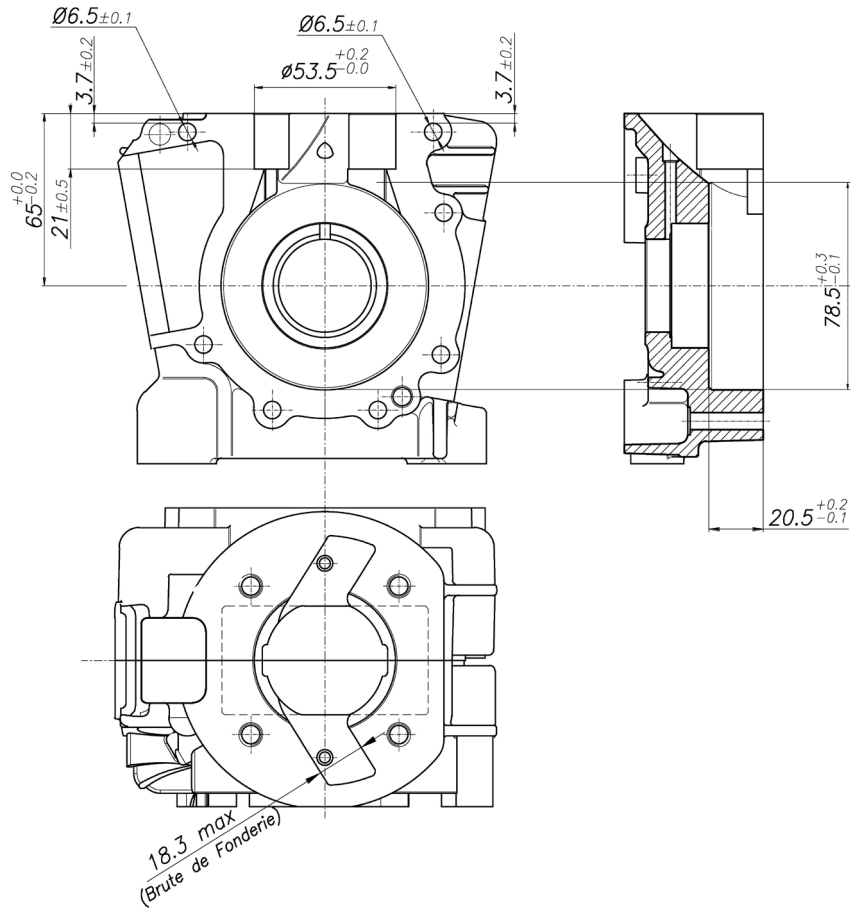

**VENTURI CARB. DIMENSIONS and THERMAL SPACERS
CARBURATEUR ET SONS ENTRETOISES**

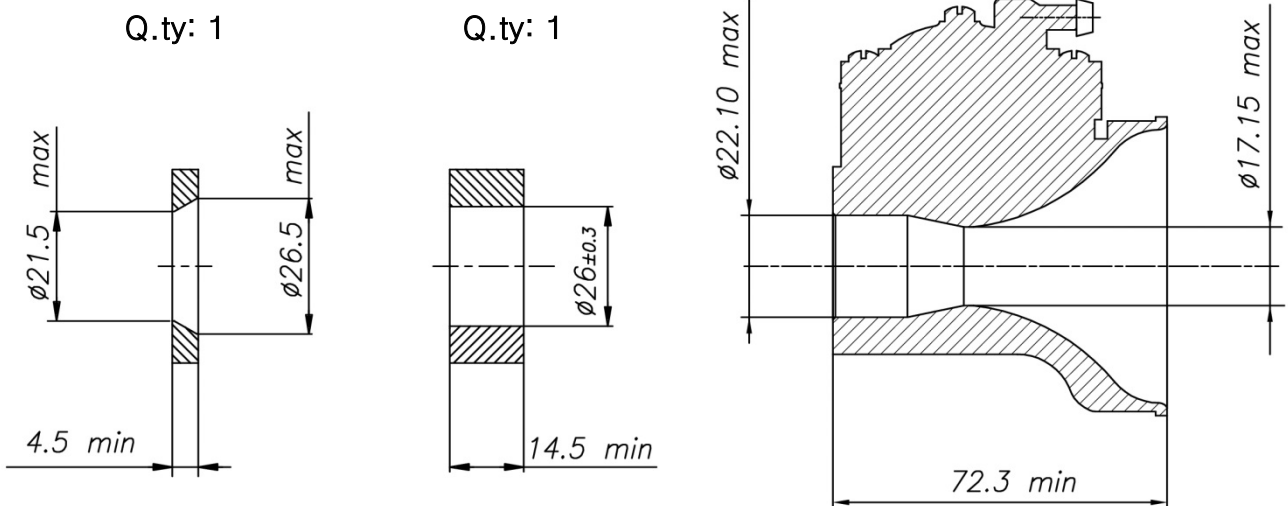

TILLOTSON MOD. HW-31A

DESCRIPTION OF THE CLUTCH – DESCRIPTION DE L'EMBRAYAGE

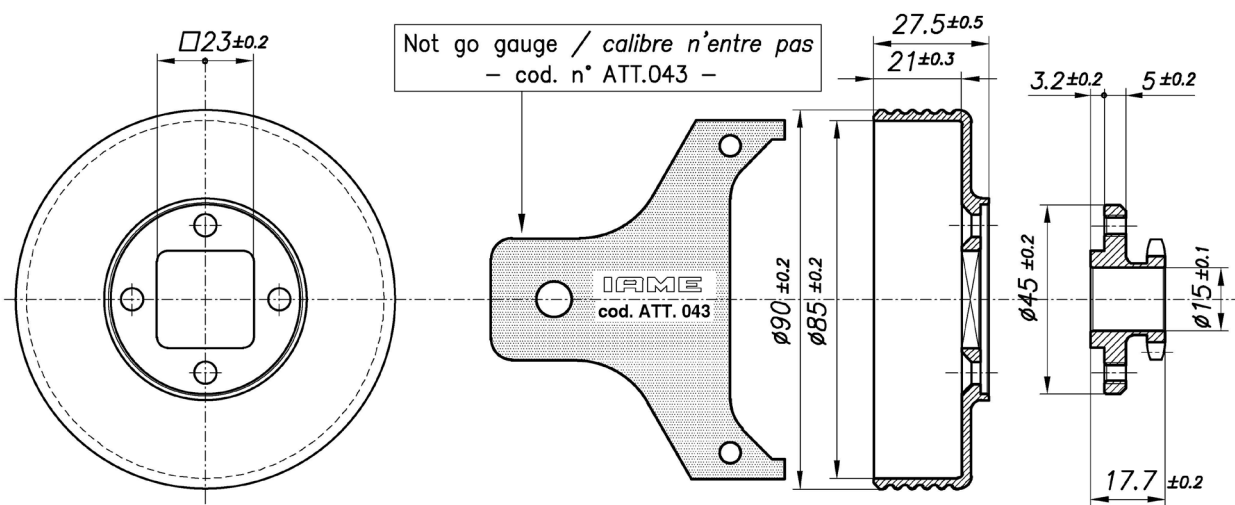
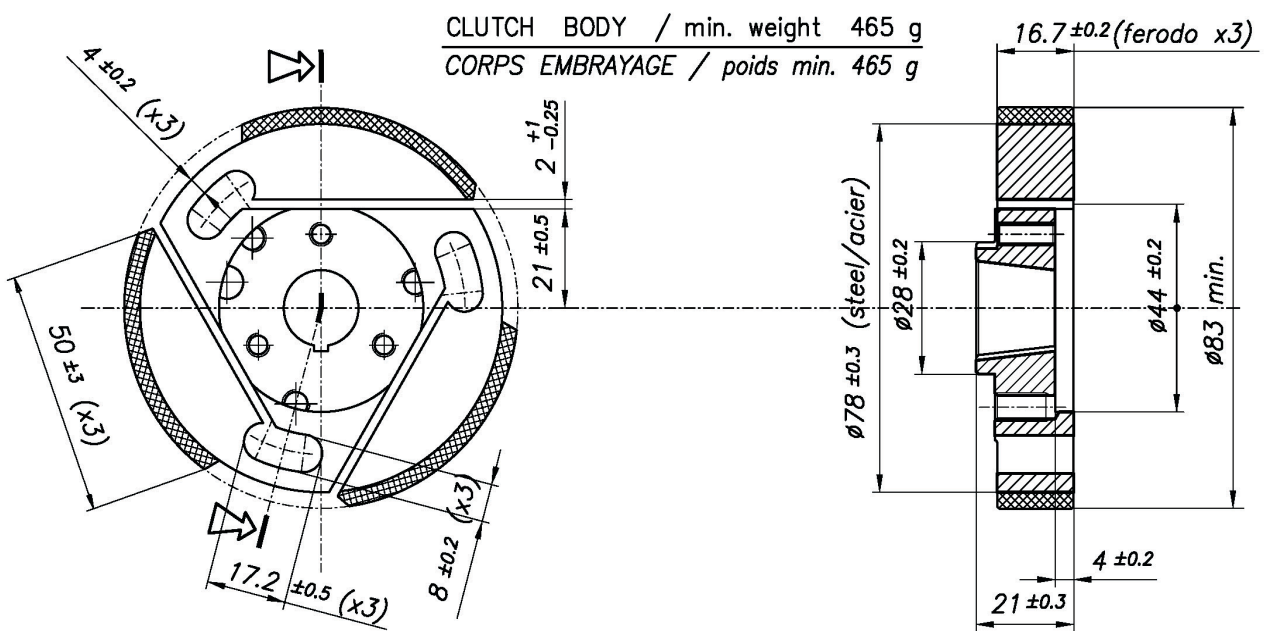
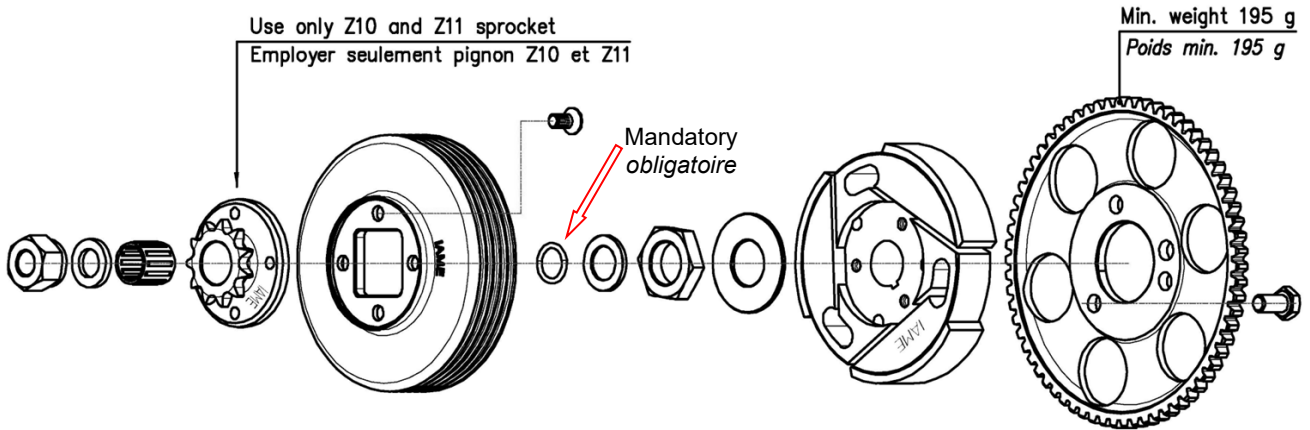

CLUTCH DRUM / min. weight 175 g
CLOCHE D'EMBRAYAGE / poids min. 175 g

DRIVE SPROCKET / min. weight 68 g
PIGNON / poids min. 68 g

EXHAUST VIEW AND DIMENSIONS (with and without embossed logo)
 VUE ET DIMENSIONS DE L'ÉCHAPPEMENT (avec et sans logo en relief)

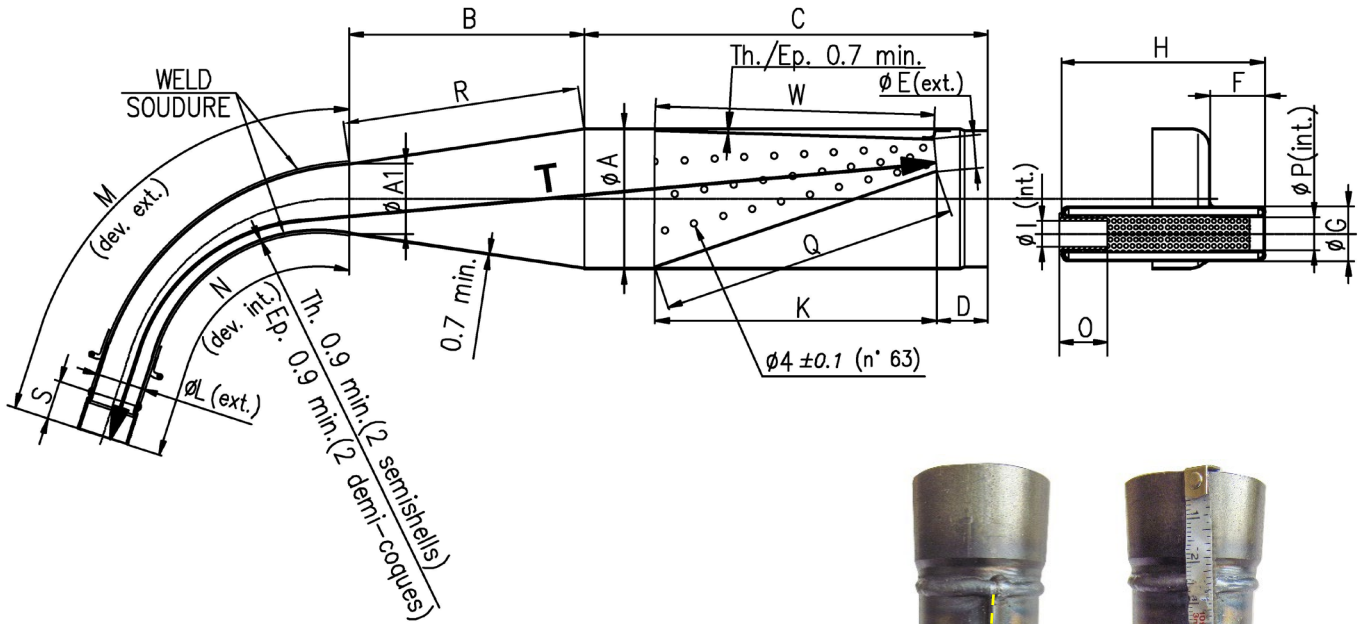

The tape must follow the centerline of the weld at all points.
 Le ruban doit suivre l'axe de la soudure en tous points.

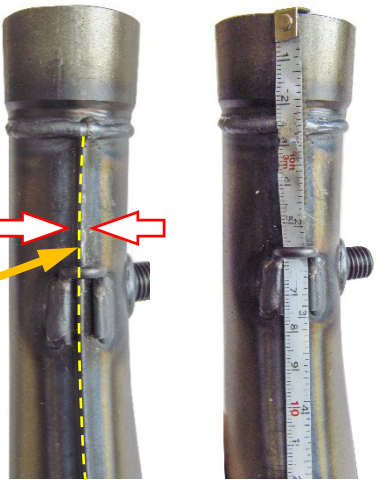

Min. weight 1250 g
 Poids min.

ØA: 90 ±1.5 Øext.	D: 30 ±2	H: 132 ±2	M: 265 ±3	R: 152 ±3	T: 601 ±3
ØA1: 45 ±1 Øext.	ØE: 20 ±1 Øext.	ØI: 17 max Øint.	N: 215 ±3	S: 25 ±1	
B: 150 ±3	F: 35 ±2	K: 181 ±3	O: 30 min.	Q: 192 ±3	
C: 260 ±3	ØG: 35 ±1 Øext.	ØL: 31 ±1.5 Øext.	ØP: 21 ±1 Øint.	W: 181 ±3	

ATTENTION:

The dimensions “**M**”, “**N**” and “**T**” must be taken by steel tape measure 6mm wide.
 Les dimensions « **M** », « **N** » et « **T** » doivent être à l'aide d'un ruban à mesurer en acier 6 mm de large.

The dimensions “**M**” and “**N**” must be taken on the weld centerline.
 Les dimensions « **M** », « **N** » doivent être prises sur l'axe de la soudure.

The dimensions “**Q**” and “**W**” must be taken by steel tape measure 12mm wide.
 Les dimensions « **Q** » et « **W** » doivent être prises à l'aide d'un ruban à mesurer en acier 12 mm de large.

ALTERNATIVE EXHAUST MUFFLER with embossed logo
ECHAPPEMENT ALTERNATIVE avec logo en relief



MARKING / MARQUAGE

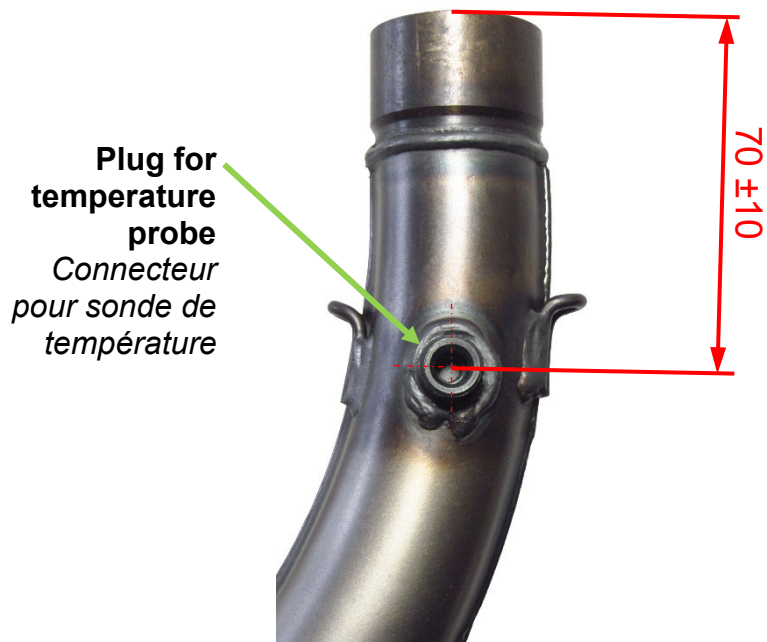

EXHAUST MANIFOLD
RACCORD D'ÉCHAPPEMENT

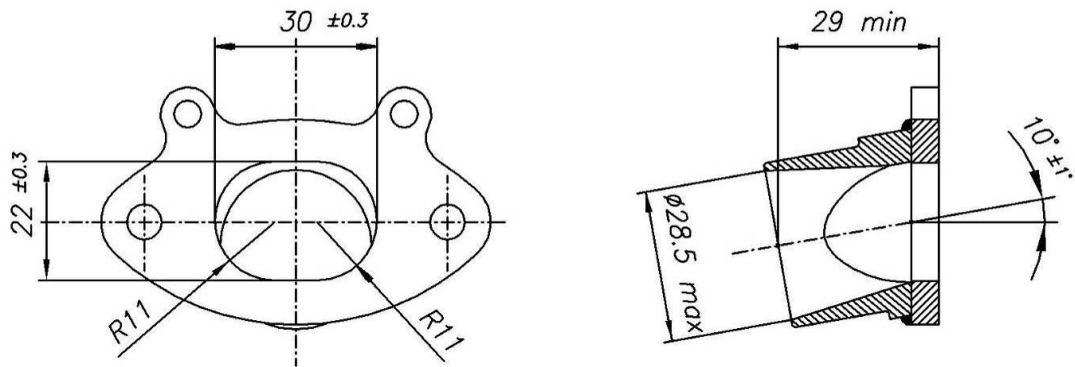

EXHAUST MANIFOLDS WITH RESTRICTED
RACCORDS AVEC RECSTRICTEUR D'ÉCHAPPEMENT

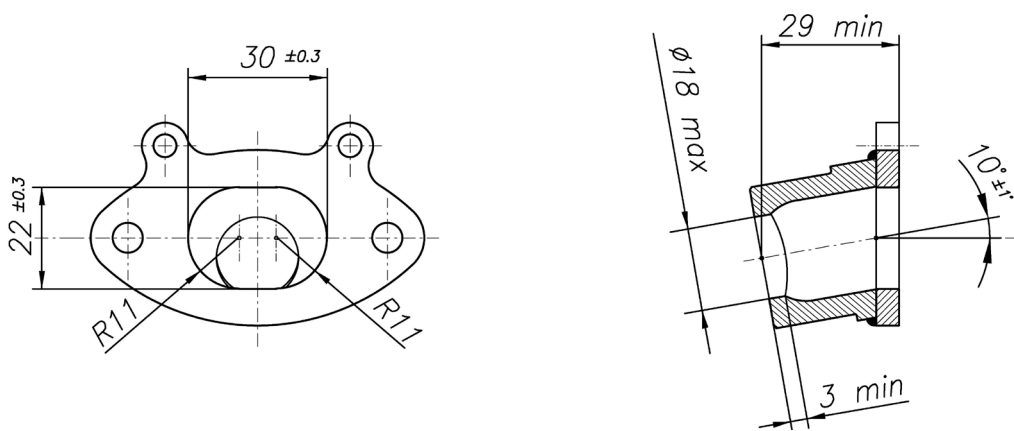
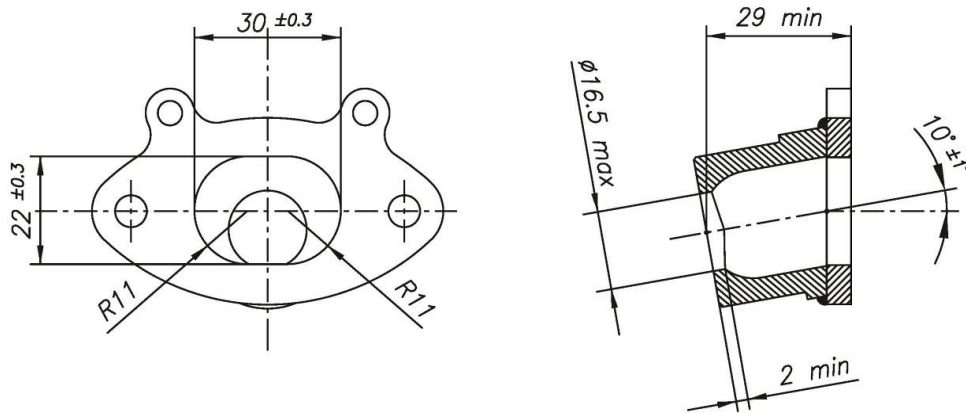

INLET SILENCER – SILENCIEUX D'ASPIRATION

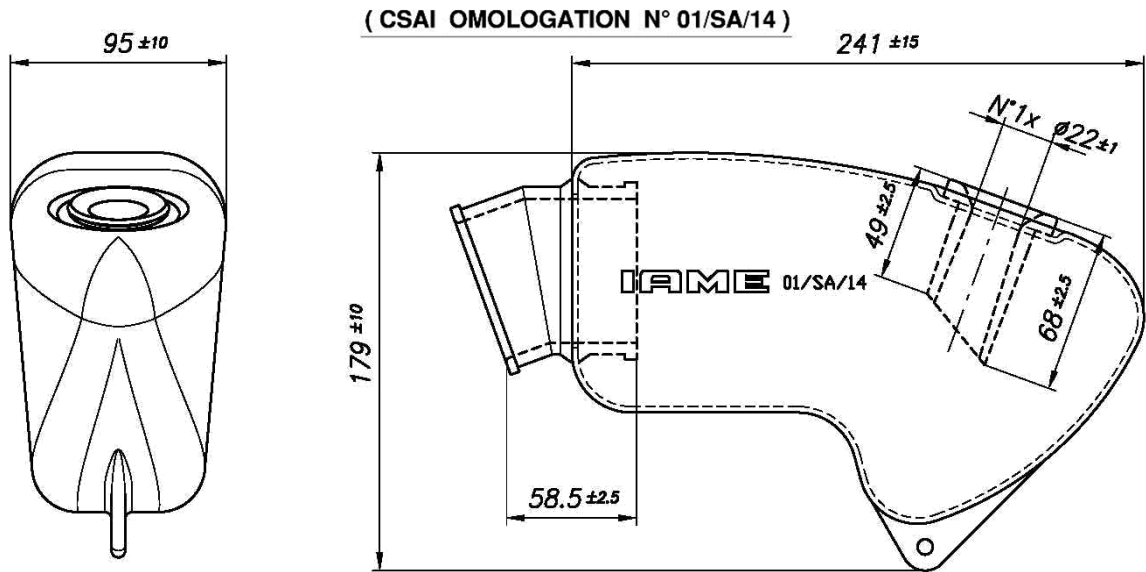

ALTERNATIVE
MANIFOLD WITH SPONGE FILTER
COLLECTEUR AVEC UNE EPONGE
FILTRE

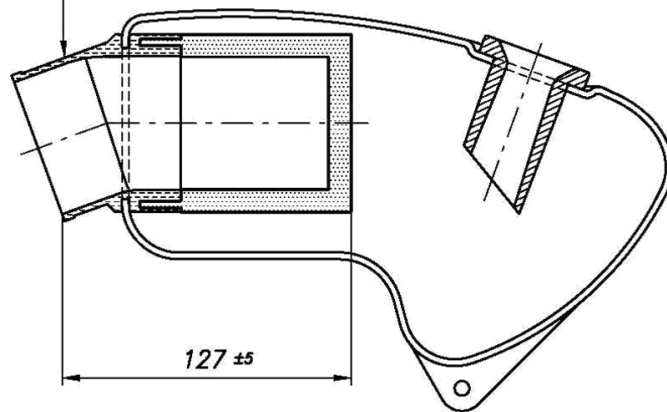

INLET SILENCER - PHOTO PHOTO - SILENCIEUX D'ASPIRATION



WIRING DIAGRAM
SCHÉMA CIRCUIT ÉLECTRIQUE

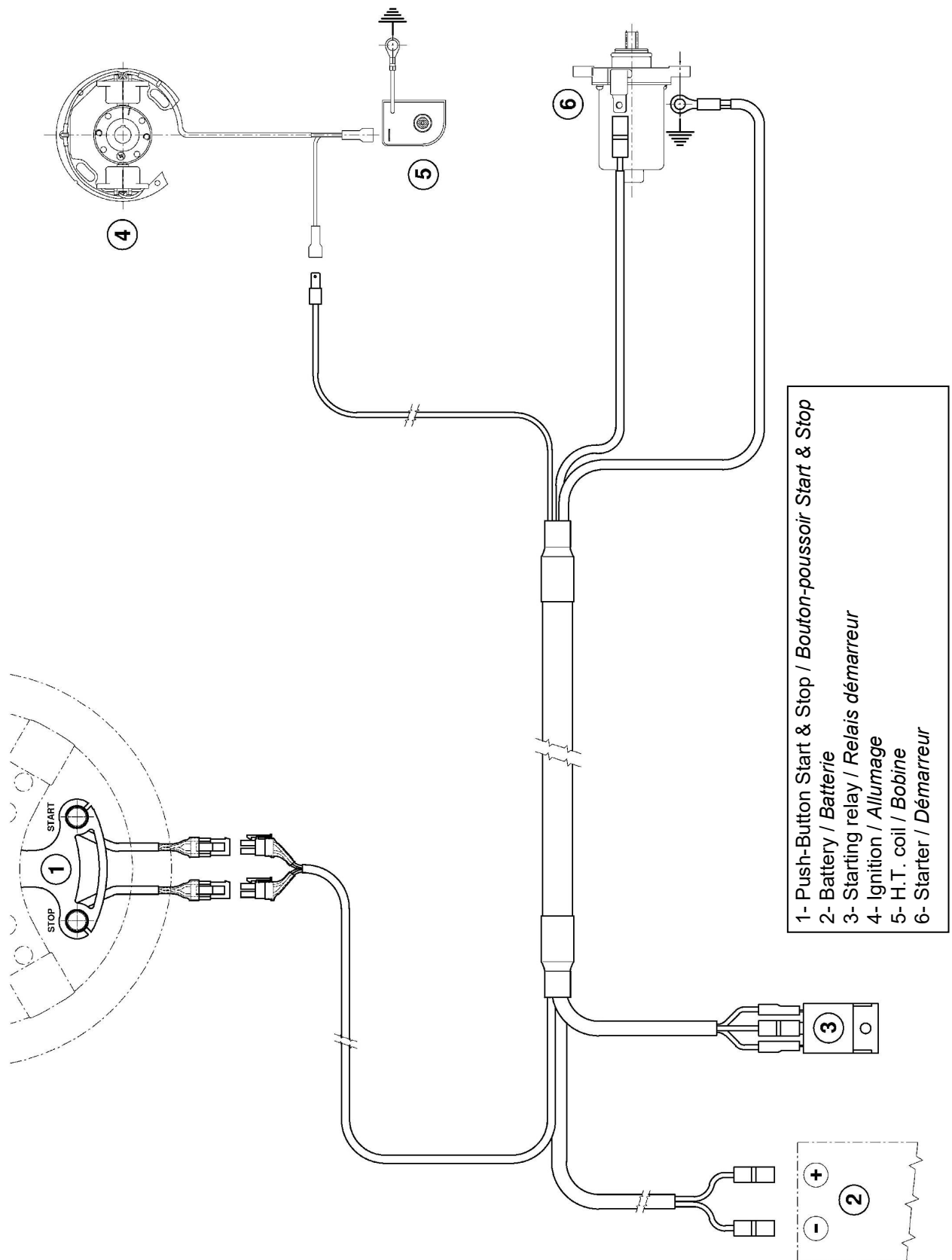

PHOTO COMPLETE WIRING
PHOTO DU CÂBLAGE ÉLECTRIQUE COMPLÈTE

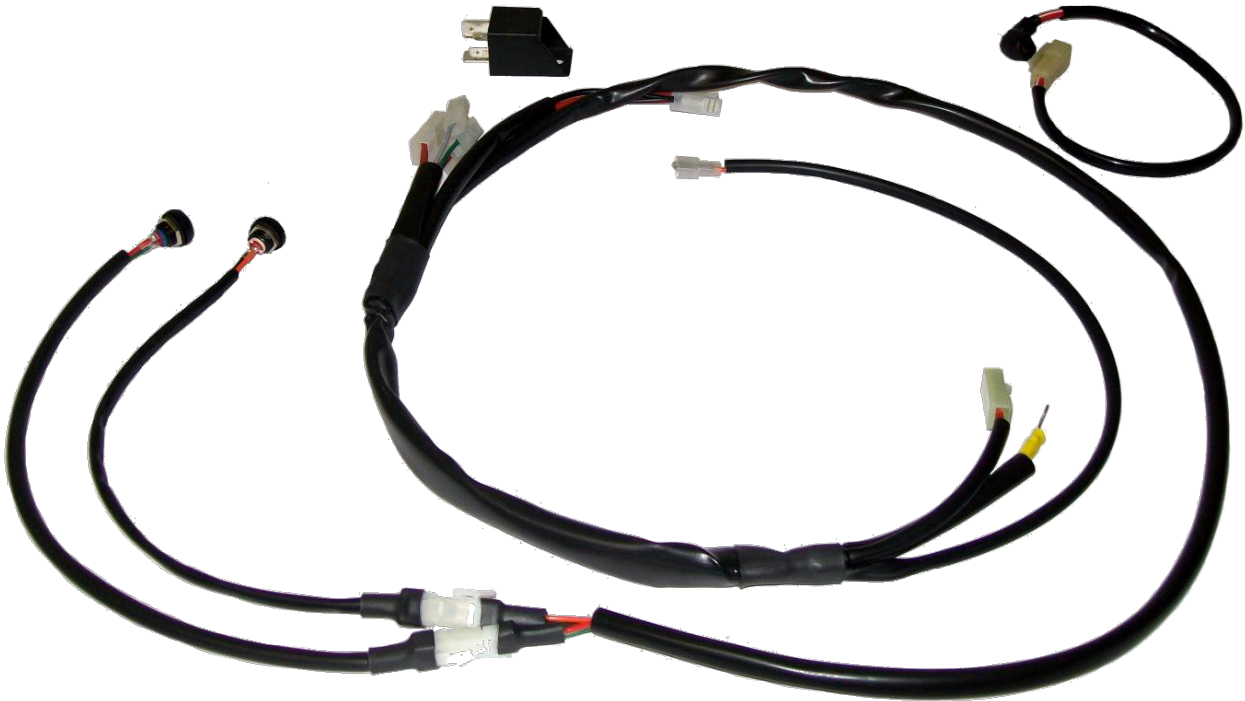
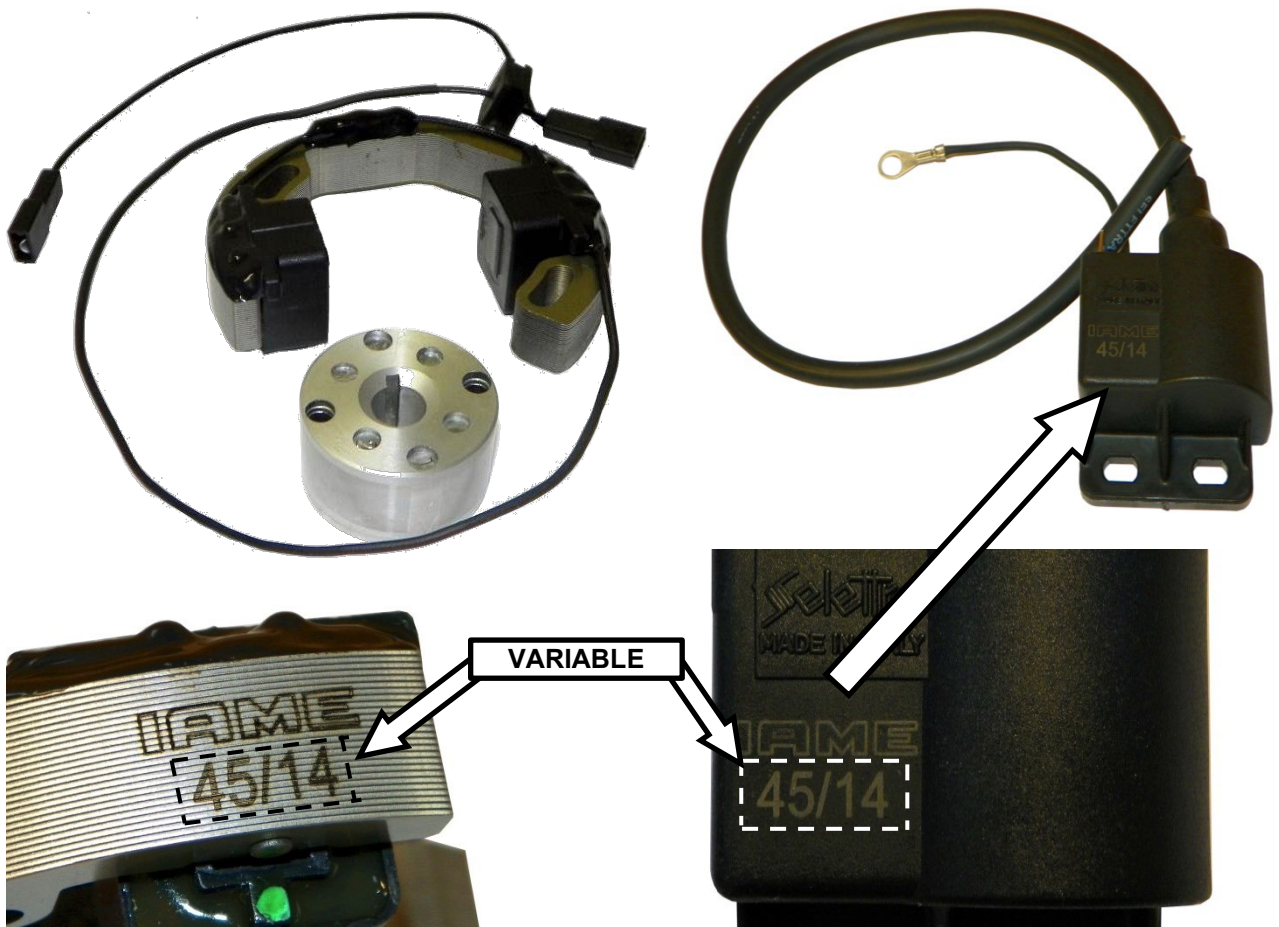
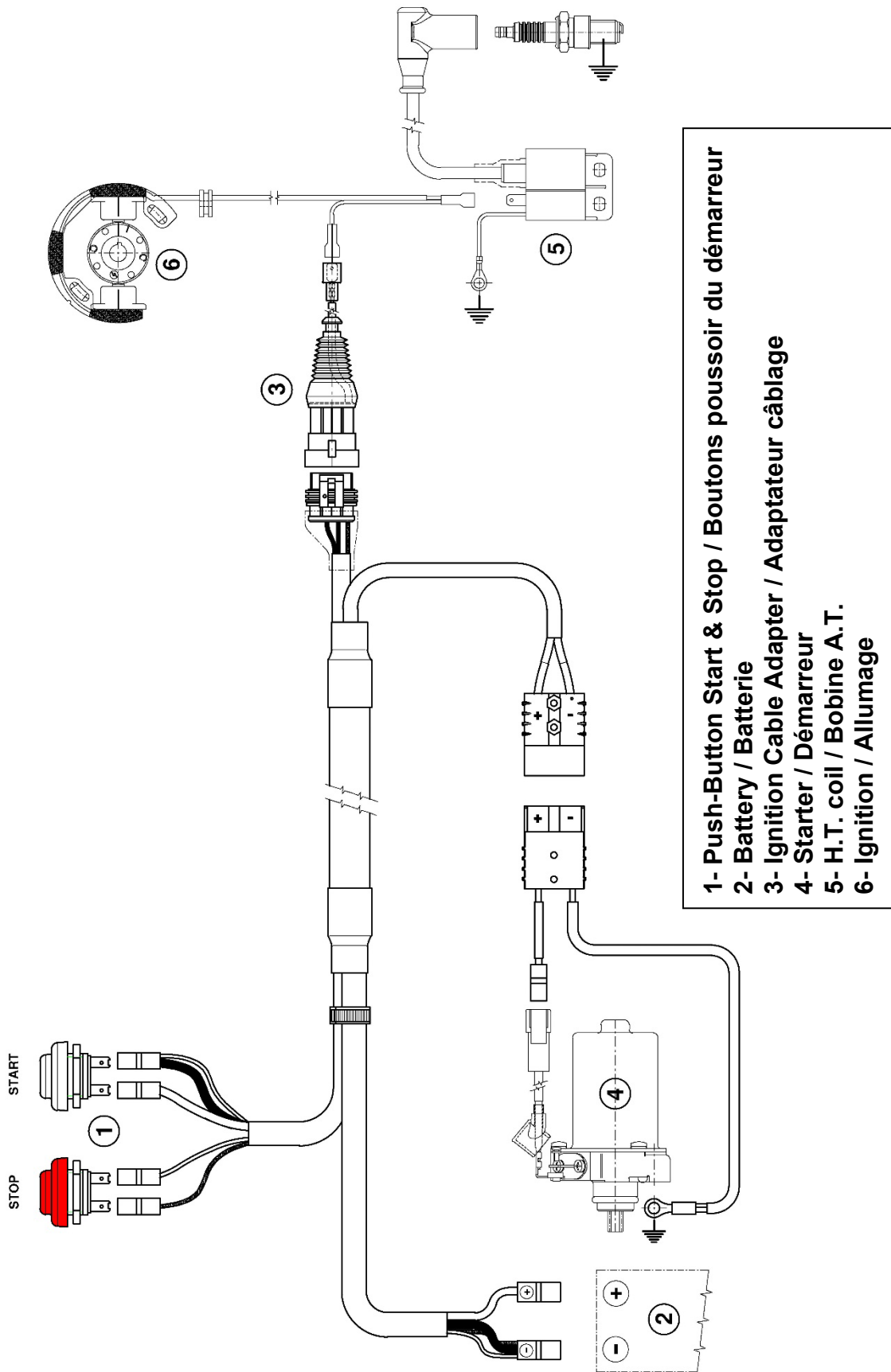

PHOTO IGNITION / PHOTO H.T. COIL (SELETTA ANALOGUE 2 POLES)
PHOTO ALLUMAGE / PHOTO BOBINE (SELETTA ANALOGIQUE 2 POLES)



ALTERNATIVE WIRING LOOM DIAGRAM
 SCHÉMA CIRCUIT ÉLECTRIQUE ALTERNATIF



- 1- Push-Button Start & Stop / Boutons poussoir du démarreur
- 2- Battery / Batterie
- 3- Ignition Cable Adapter / Adaptateur câblage
- 4- Starter / Démarreur
- 5- H.T. coil / Bobine A.T.
- 6- Ignition / Allumage

PHOTO OF ALTERNATIVE COMPLETE WIRING LOOM
PHOTO DU CÂBLAGE ÉLECTRIQUE COMPLÈTE ALTERNATIF



WATER PUMP ALTERNATIVES – ALTERNATIVES DU POMPE A' EAU

WATER PUMP IS FREE

26 FEBRUARY 2024

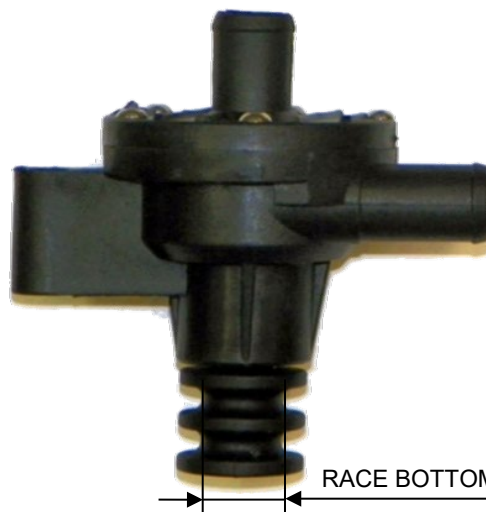

PLASTIC

RACE BOTTOM FOND GORGE $\varnothing 19 \pm 1$

ALTERNATIVE

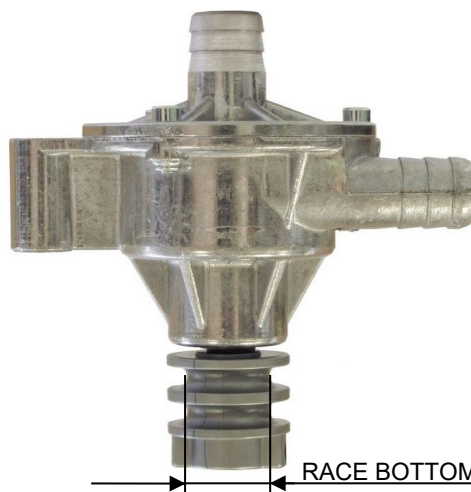

ALUMINUM

RACE BOTTOM - FOND GORGE $\varnothing 20 \pm 1$

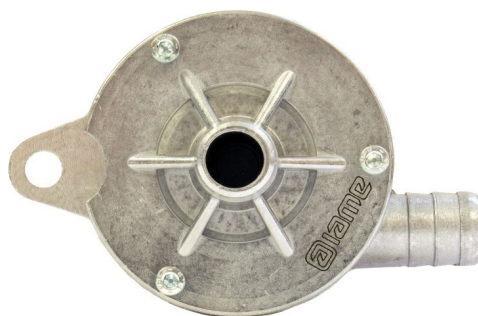

PULLEY ALTERNATIVE – ALTERNATIVE DU POULIE

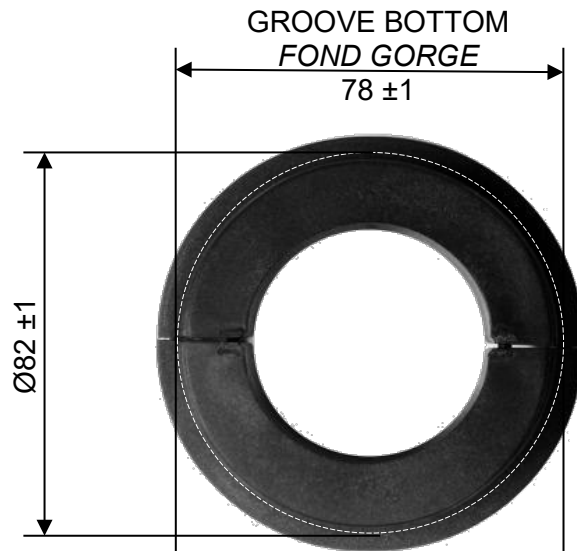

PLASTIC

PULLEY IS FREE
26 FEBRUARY 2024



ALTERNATIVE



ALUMINUM

RADIATOR AND ITS SUPPORTS
RADIATEUR ET SES SUI TIEN

PAINTED AND NOT PAINTED
PEINT ET PAS PEINT

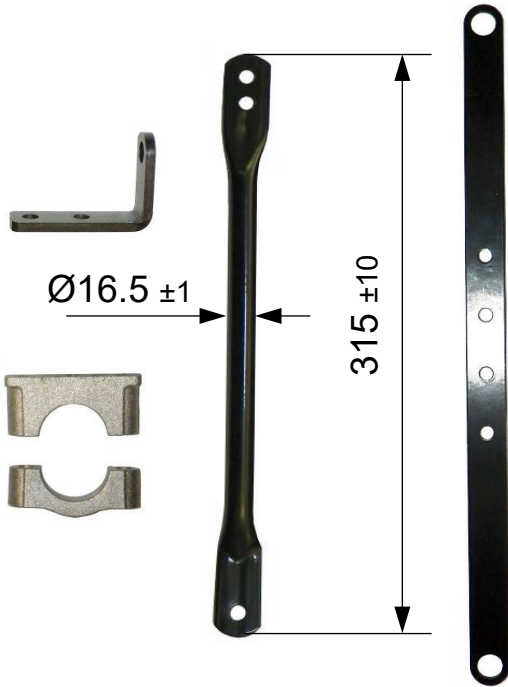

ALTERNATIVE RADIATOR
RADIATEUR ALTERNATIF

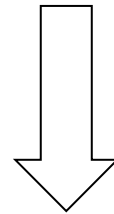
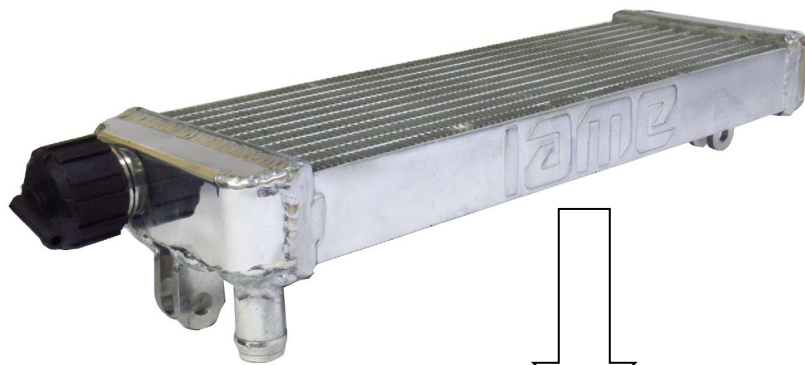

ALTERNATIVE RADIATOR SUPPORT
ALTERNATIVE SUI TIEN DU RADIATEUR



$\text{Ø}16.5 \pm 1$

315 ± 10

CYLINDER IDENTIFICATION MARKING
MARQUAGE D'IDENTIFICATION DU CYLINDRE

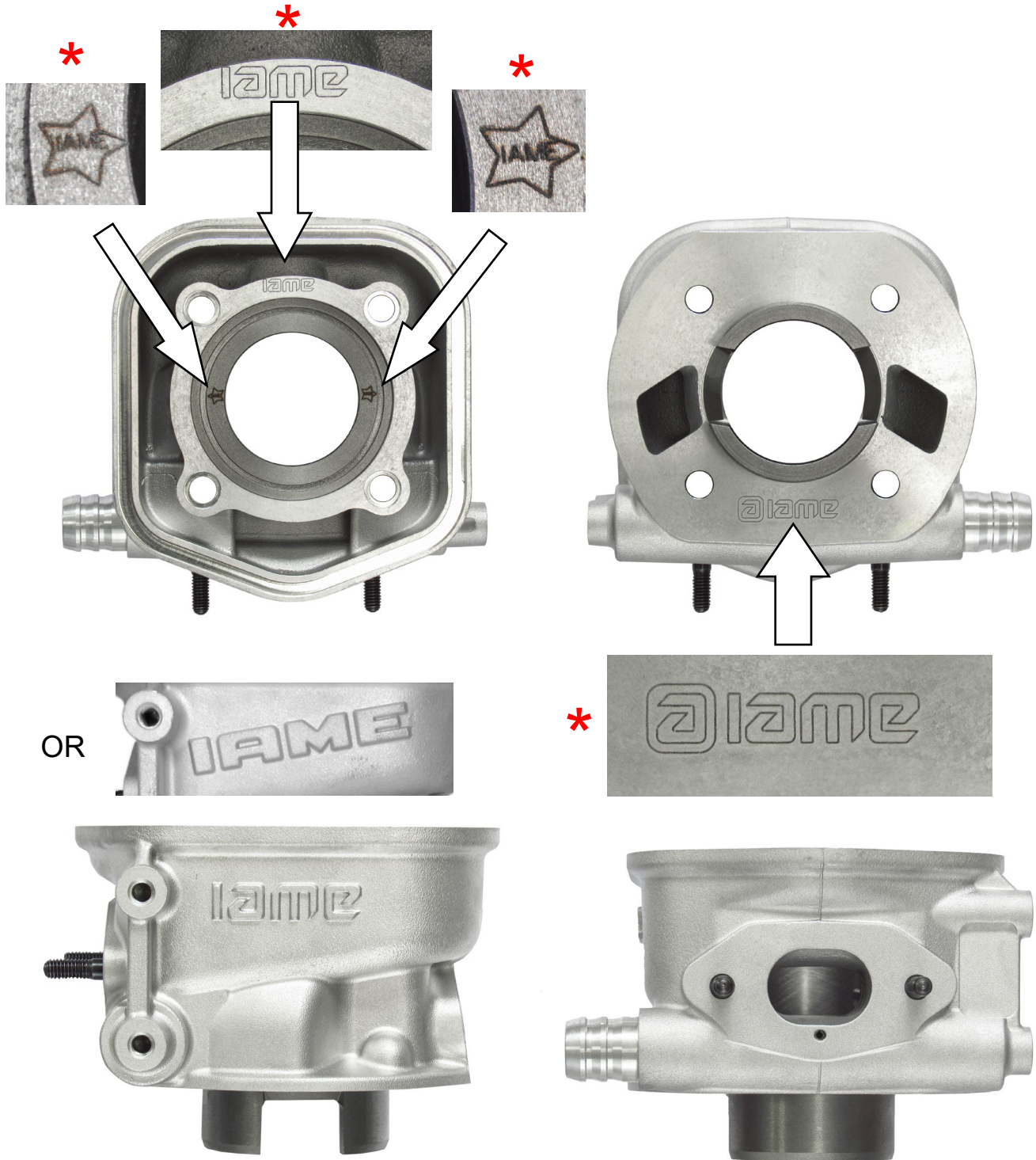

* Compulsory from engine n. 011150
Obligatoire à partir du moteur no. 011150

CYLINDER BASE ALTERNATIVE MARKING
MARQUAGE ALTERNATIF DU LA BASE CYLINDRE

ALTERNATIVE

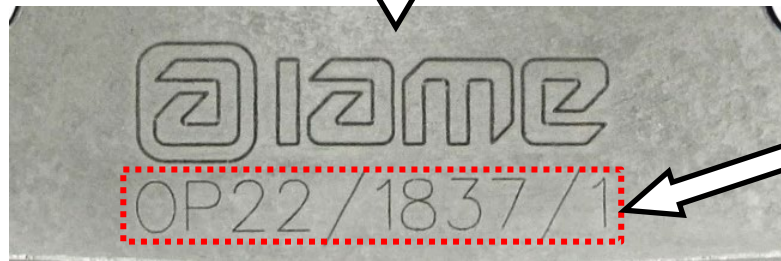

VARIABLE

CYLINDER HEAD MARKING
MARQUAGE D'IDENTIFICATION DU CULASSE

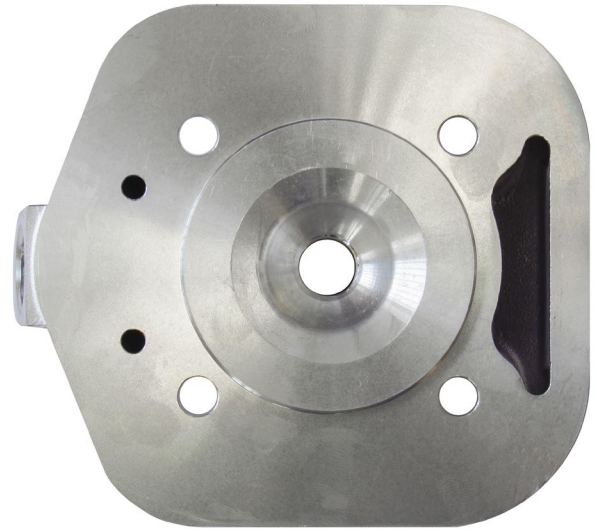
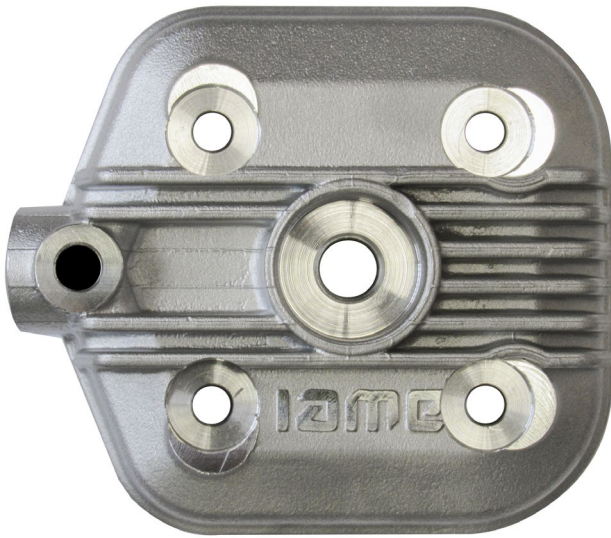

OR



SEMICARTER TRANSMISSION SIDE
SEMICARTER CÔTÉ PIGNON

SEMICARTER IGNITION SIDE
SEMICARTER CÔTÉ ALLUMAGE

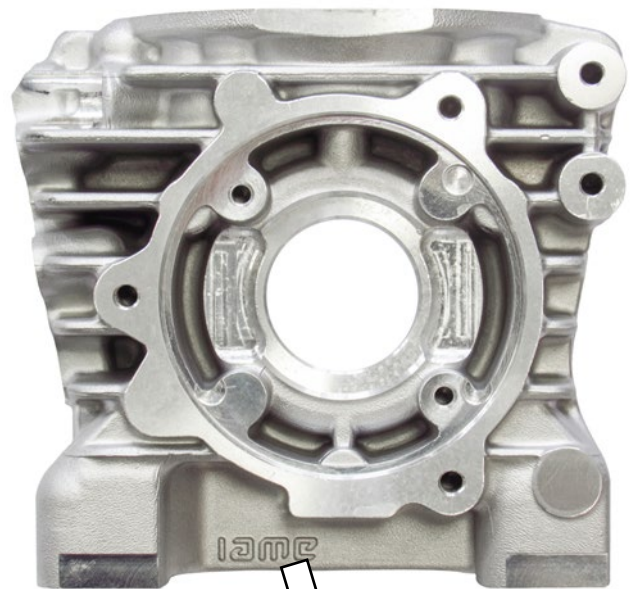
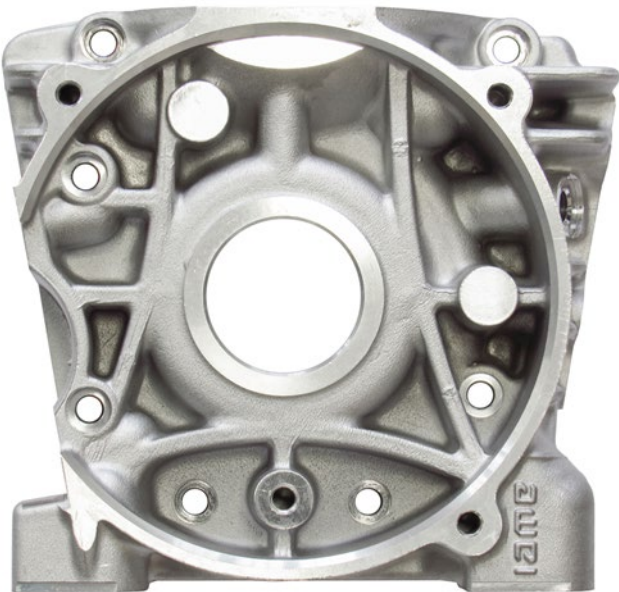

OR

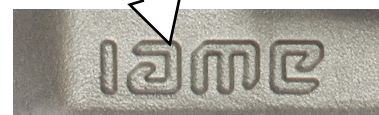

OR



PHOTO IDENTIFICATION OF CONROD – TYPES ALTERNATIVE
PHOTO D' IDENTIFICATION DE LA BIELLE – TYPES ALTERNATIFS

TYPE 1



TYPE 2



PISTON IT1 TYPES IDENTIFICATION
IDENTIFICATION DES TYPES DU PISTON IT1
(dimensions and weight are the same for both types /
les dimensions et le poids sont les mêmes pour les deux types)

CURRENT / COURANT

ALTERNATIVE / ALTERNATIF

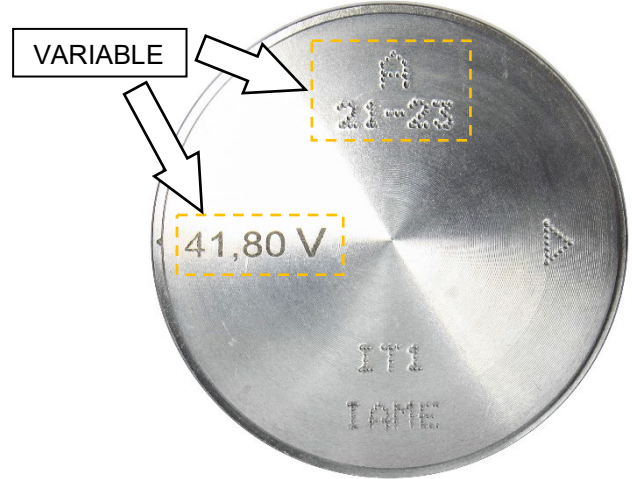
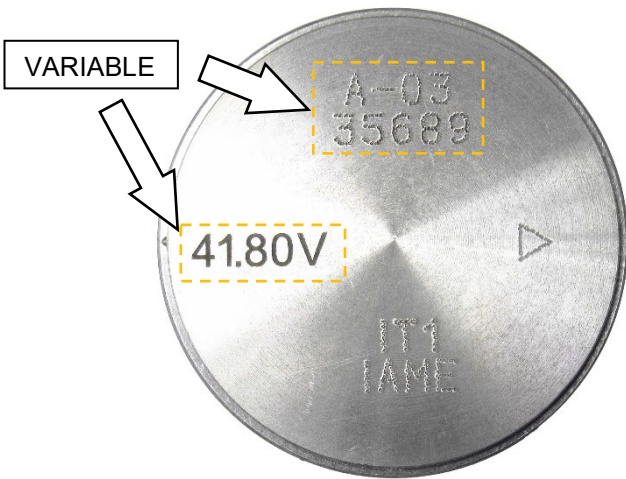

SPROCKET IDENTIFICATION MARKING
MARQUAGE D'IDENTIFICATION DU PIGNON

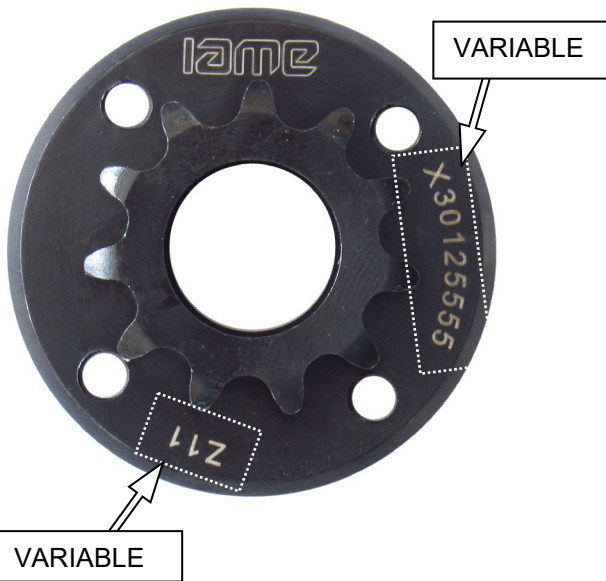

CLUTCH DRUM IDENTIFICATION MARKING
MARQUAGE D'IDENTIFICATION DE LA CALOTTE

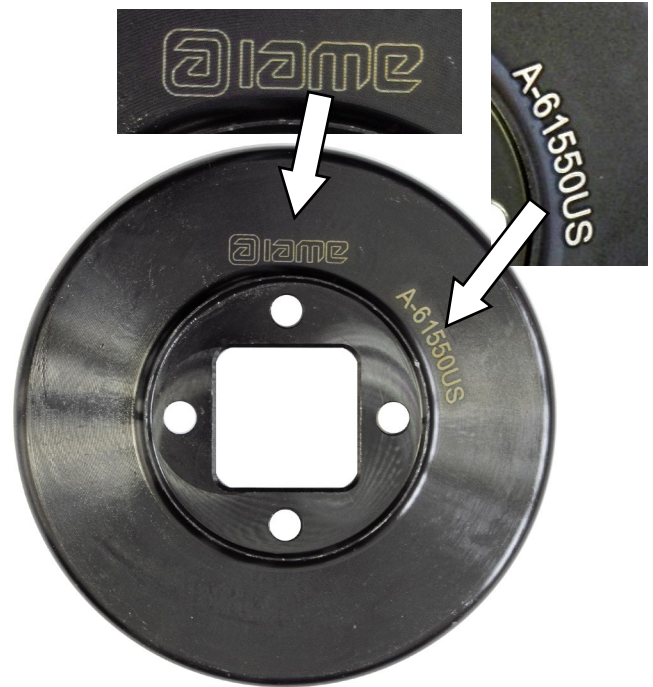

CLUTCH BODY IDENTIFICATION MARKING
MARQUAGE D'IDENTIFICATION DU CORPS DE L'EMBAYAGE



STARTER RING IDENTIFICATION MARKING
MARQUAGE D'IDENTIFICATION DE LA COURONNE DE DEMARRAGE



CRANKSHAFT AND HIS COMPONENTS IDENTIFICATION MARKING
 MARQUAGE D'IDENTIFICATION DU VILEBREQUIN ET SES COMPOSANTS

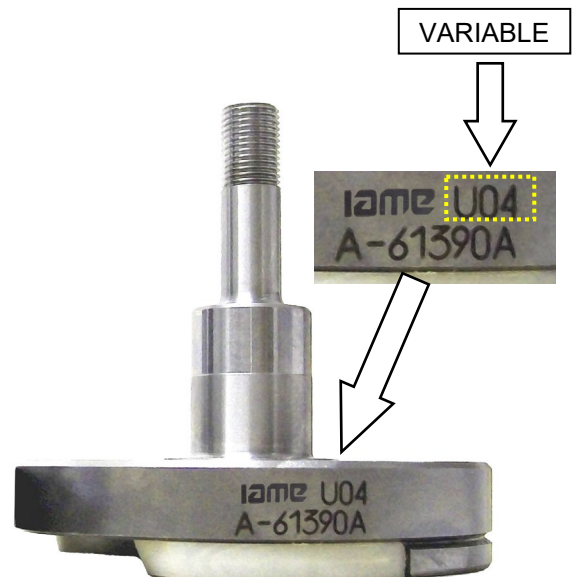
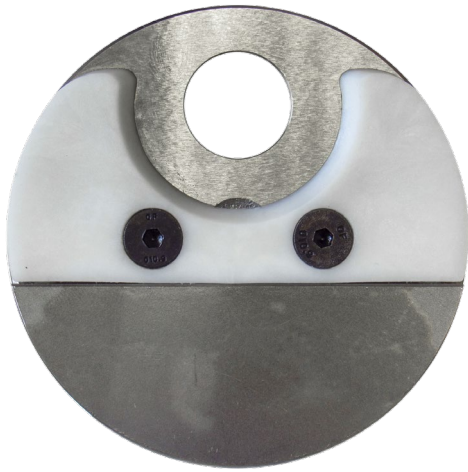

BENDIX COVER IDENTIFICATION MARKING
MARQUAGE D'IDENTIFICATION DU COUVERCLE
DU CONTRE-ARBRE DE DEMARRAGE



STARTER IDENTIFICATION MARKING
MARQUAGE D'IDENTIFICATION DU DEMARREUR

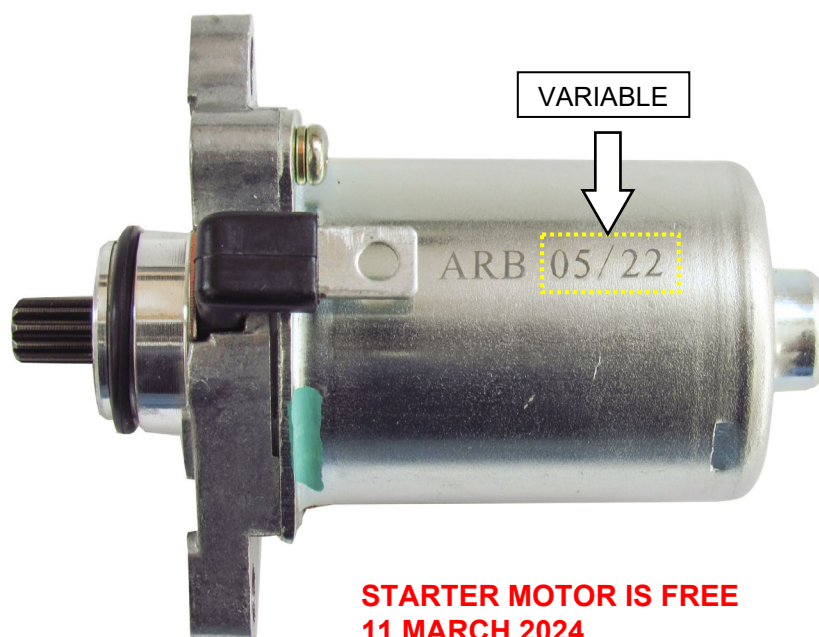
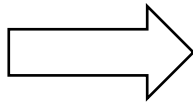
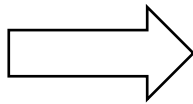

PHOTO IDENTIFICATION: SMALL & BIG END CONROD BEARING AND MAIN BEARING
PHOTO D'IDENTIFICATION DU ROULEMENT PIED/TÊTE DE BIELLE ET PRINCIPAUX



ALTERNATIVE



EXHAUST IDENTIFICATION MARKING without embossed logo
MARQUAGE D'IDENTIFICATION ECHAPPEMENT sans logo en relief

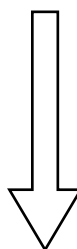
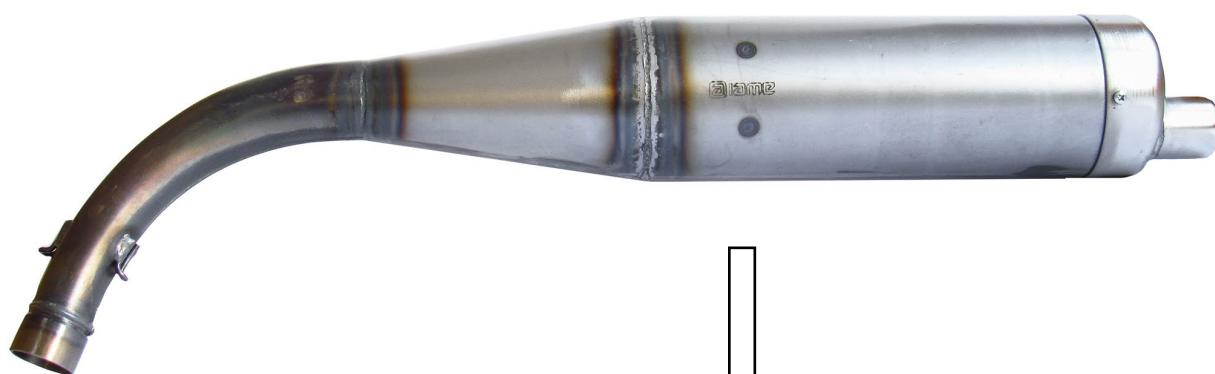

IGNITION COVER
COUVERCLE DU ALLUMAGE



OR



CLUTCH COVER
COUVERCLE D'EMBAYAGE



OR



INLET FILTER
SILENCIEUX D'ASPIRATION



OR



THE OTHERS COMPONENTS OF ENGINE THAT ARE MARKED (LASER OR PUNCHING) UNTIL TODAY WITH LOGO OR WRITTEN "IAME"

LES AUTRES COMPOSANTS DU MOTEUR AVEC MARQUAGE (LASER OU POINÇONNEUSE) AUJOURD'HUI AVEC LE LOGO OU ÉCRIT «IAME»

I A M E

or

IAME

NOW COULD BE MARKED WITH NEW LOGO "IAME"
MAINTENANT POURRAIT EST MARQUAGE AVEC UN NOUVEAU LOGO
"IAME"

I a m e

or

ⓐ I a m e

or

ⓐ

NO GO GAUGES
OUTILS N'ENTRE PAS DANS

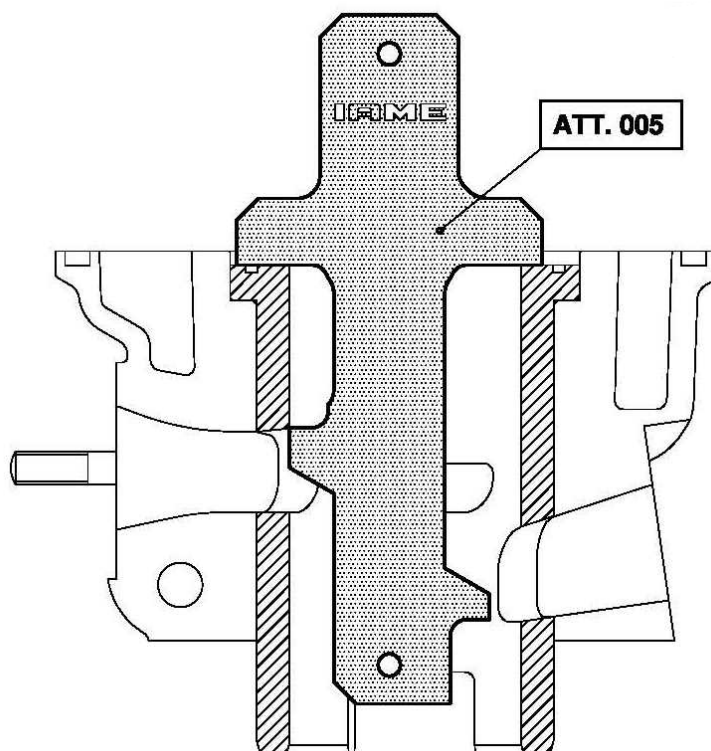
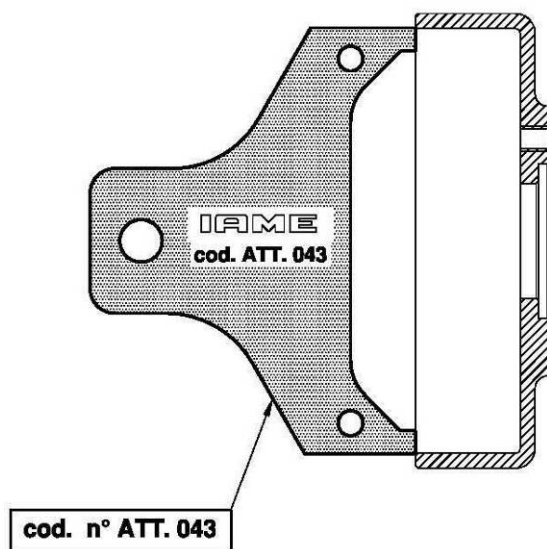

NO GO GAUGES
OUTILS N'ENTRE PAS DANS

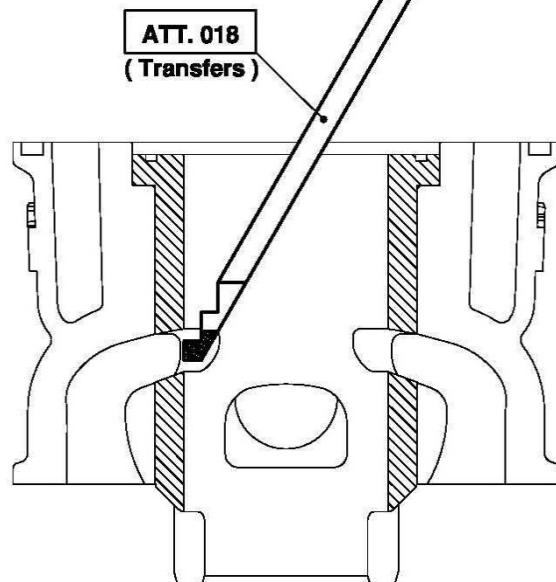
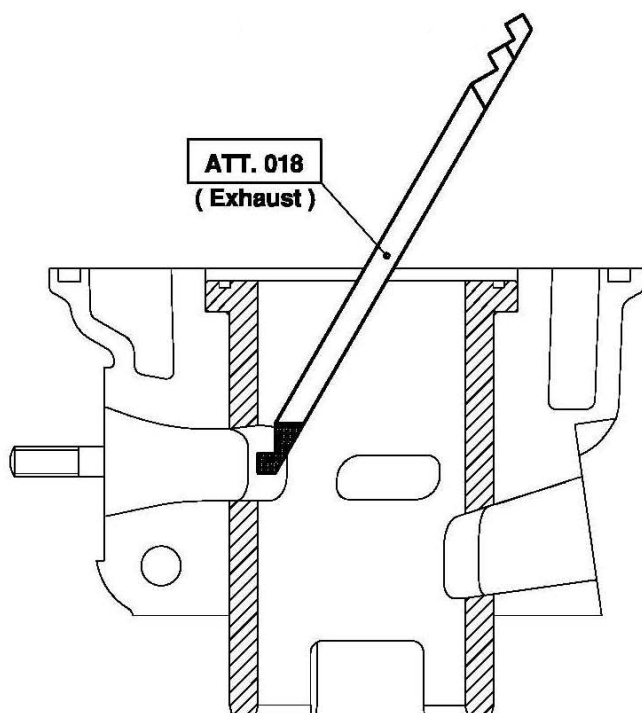
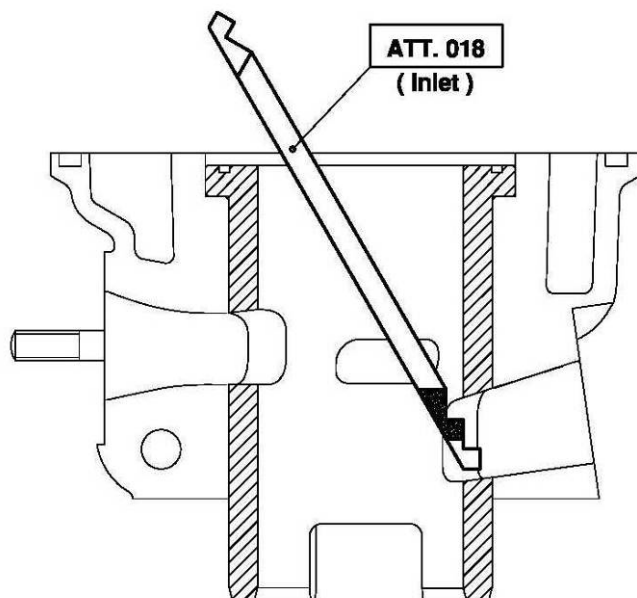

CONTROL GAUGES
OUTILS DE CONTROLL

TOOL IAME Cod. 10194

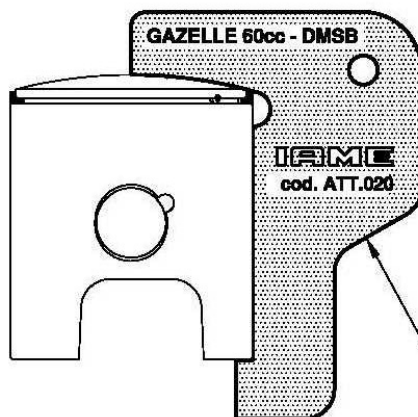
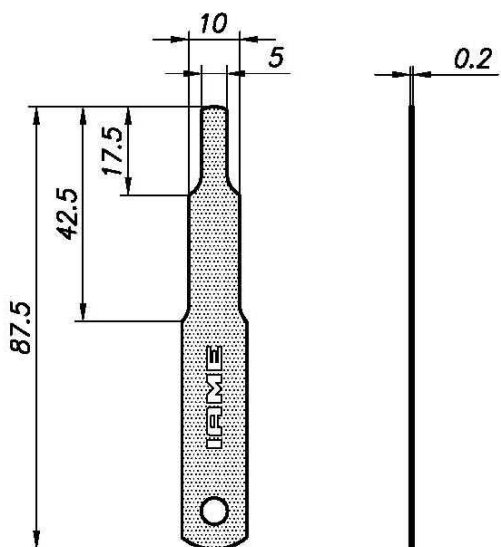

cod. n° ATT. 020

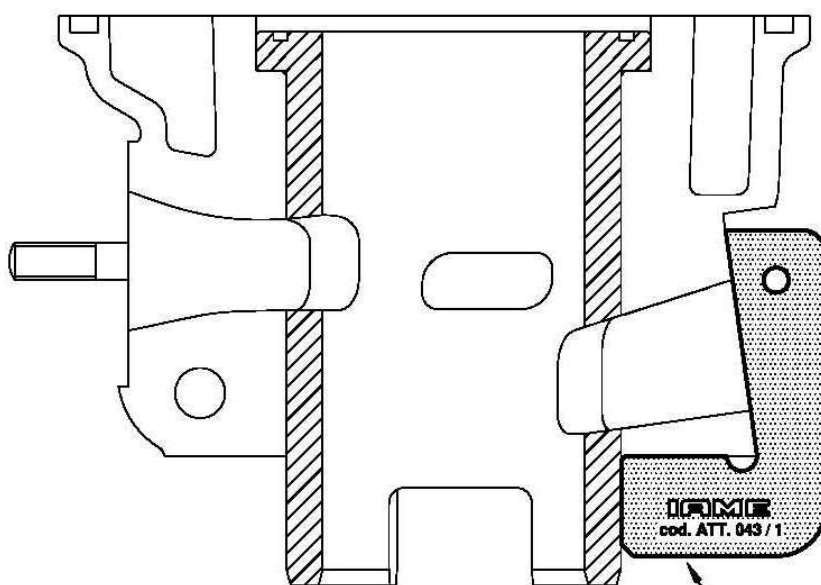

cod. n° ATT. 043 / 1

CONTROL GAUGES
OUTILS DE CONTROL

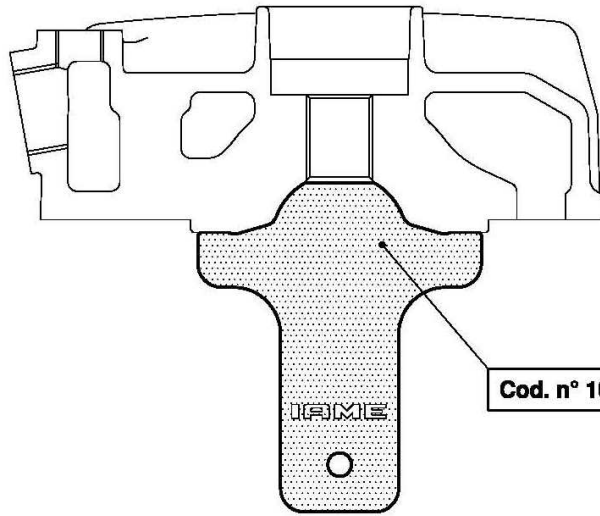

Cod. n° 10215

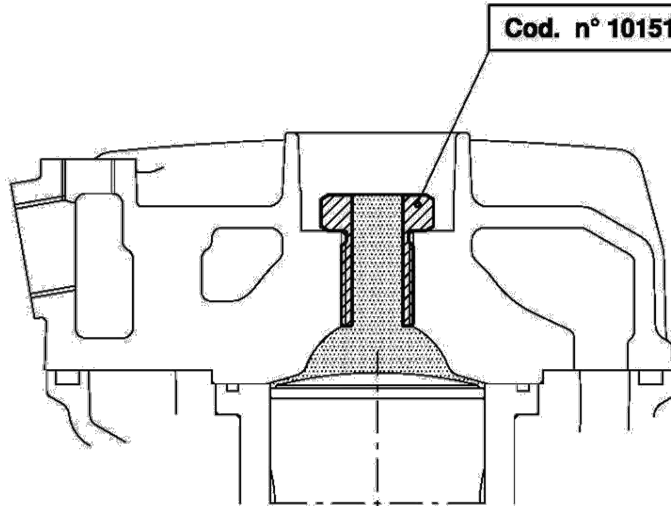

Cod. n° 10151

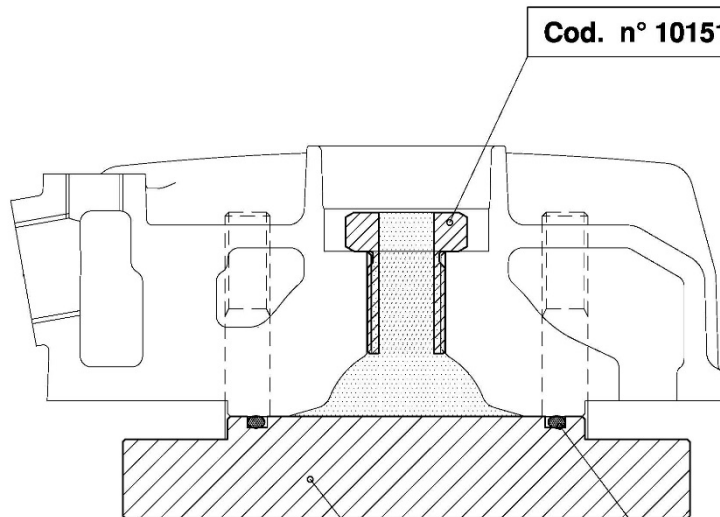

Cod. n° 10151

Cod. n° 10276

(OR - 3193)

**CONTROL GAUGES
OUTILS DE CONTROLL**

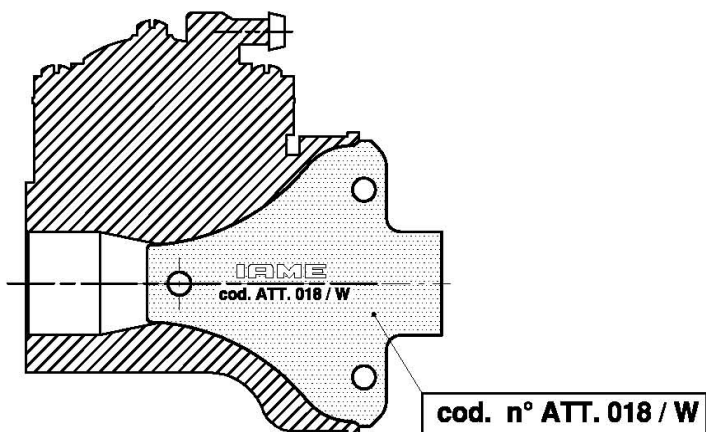

Check that the tool must be the same shape of the inlet carburettor.
Vérifier que l'outil doit avoir la même forme que l'admission du carburateur.

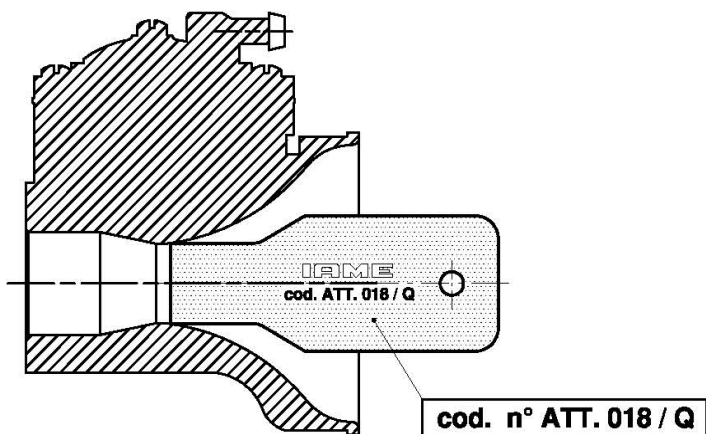

Check that the tool does not enter into the venturi duct inlet of carburettor.
Vérifier que l'outil n'entre pas dans l'entrée du conduit Venturi du carburateur.

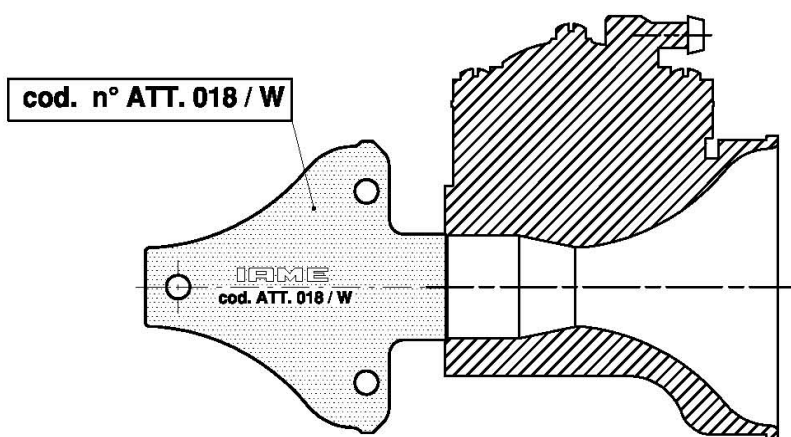

Check that the tool does not enter into the venturi duct outlet of carburettor.
Vérifier que l'outil n'entre pas dans la sortie du conduit Venturi du carburateur.

**CONTROL GAUGES
OUTILS DE CONTROLL**

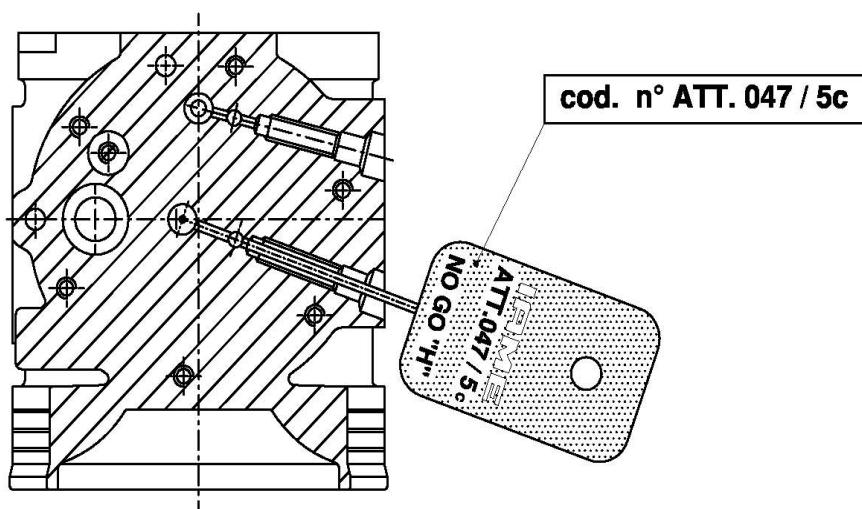
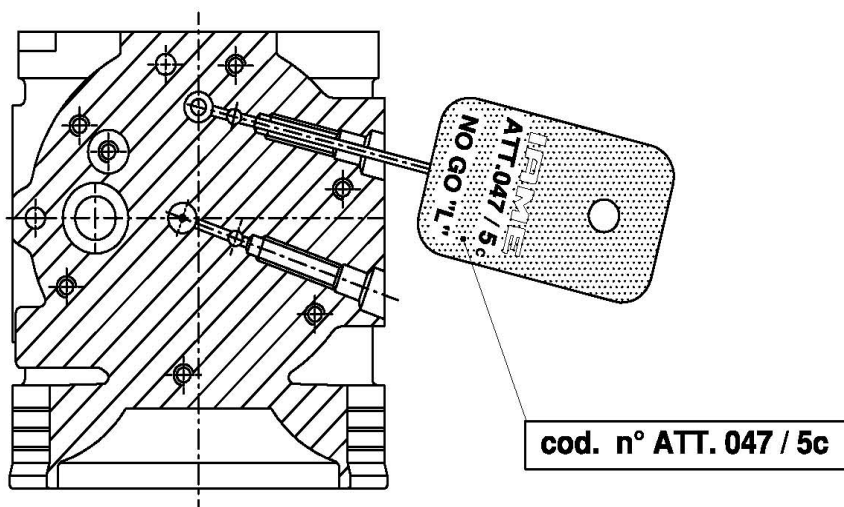

Check that the spikes does not enter into the holes.
Vérifiez que les pointes n'entrent pas dans les trous.

**CONTROL GAUGES
OUTILS DE CONTROL**

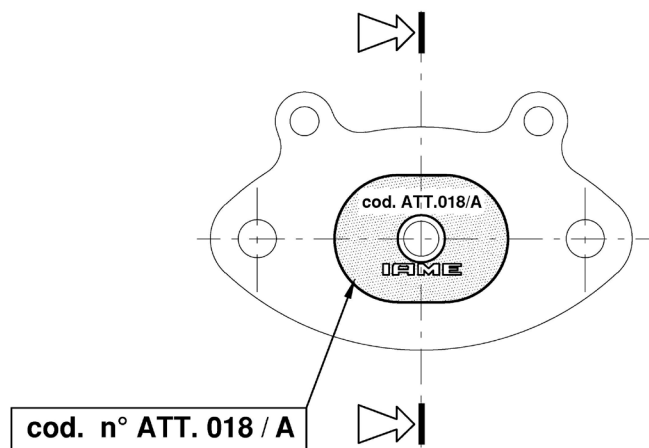
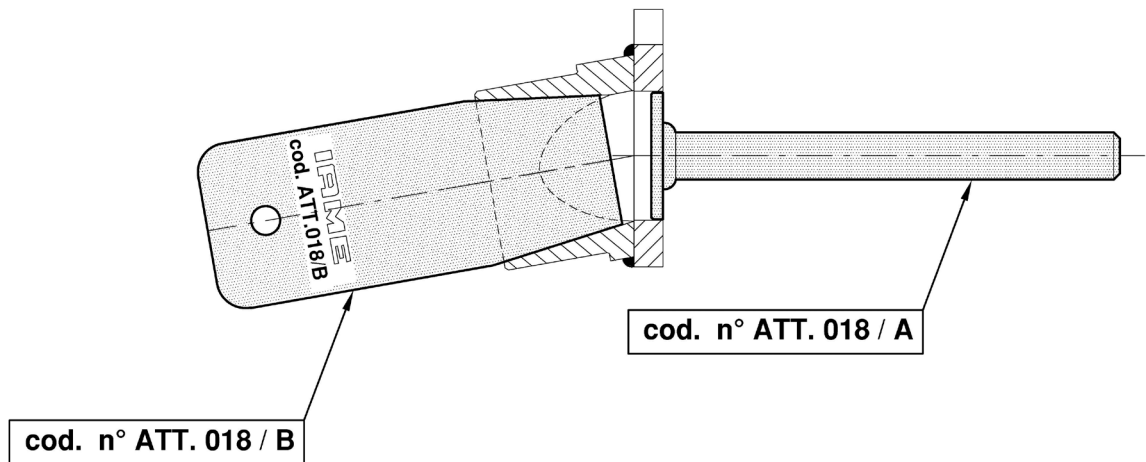

Check that the tool must be the same shape of the exhaust manifold.
Vérifiez que l'outil doit être de la même forme du collecteur d'échappement

IAME TOOLS – GABARIT DE CONTROL IAME

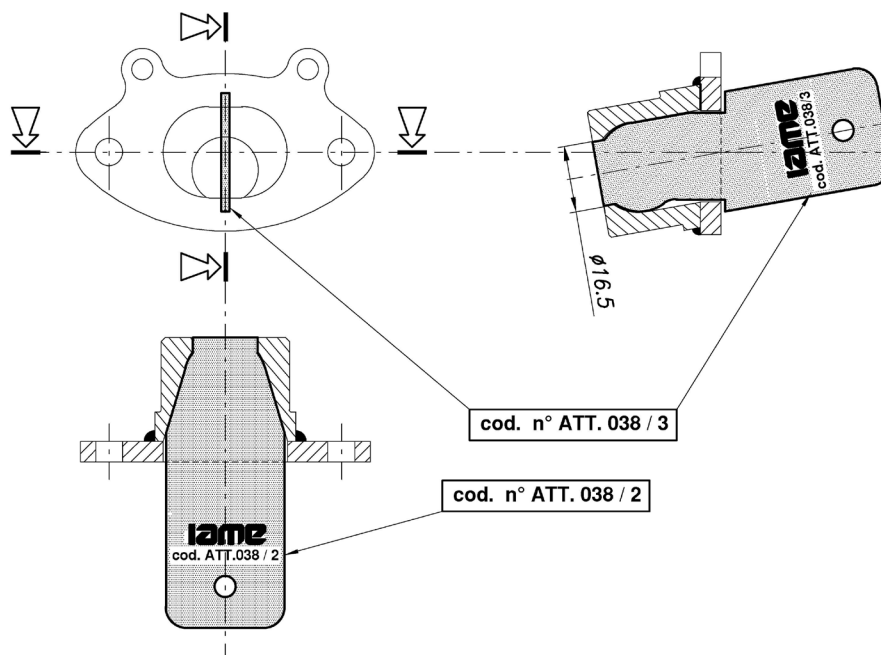

Check that the tool must be the same shape of the inlet carburettor.
Vérifier que l'outil doit avoir la même forme que l'admission du carburateur.

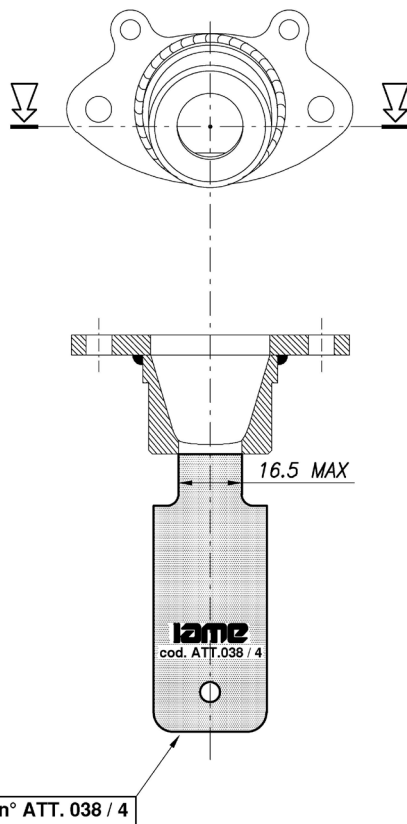

Check that the tool does not enter into the exhaust restrictor.
Vérifier que l'outil n'entre pas dans le restricteur d'échappement

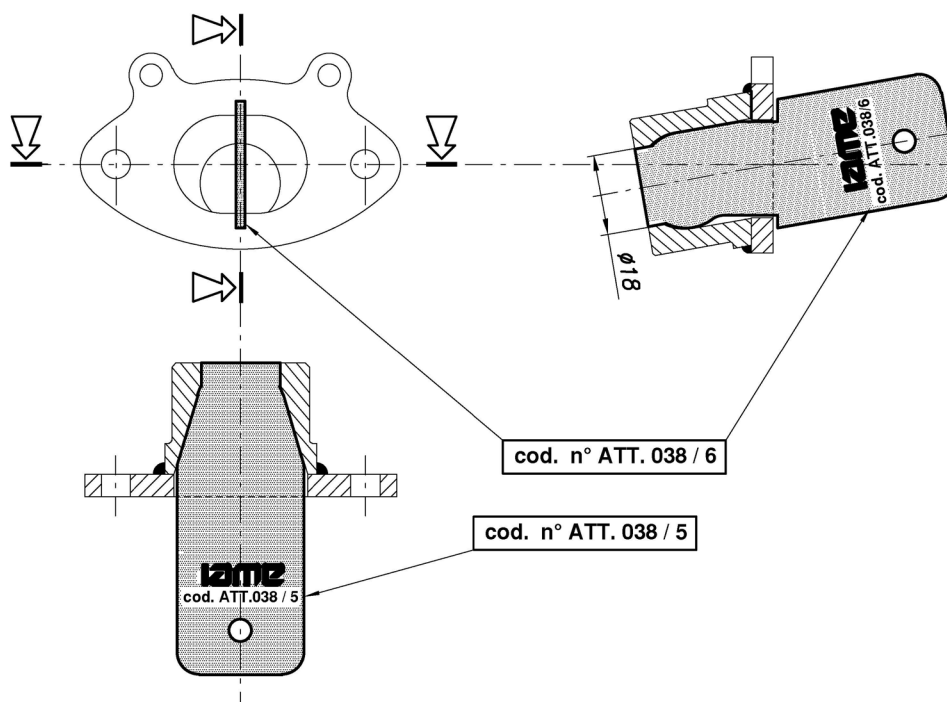

Check that the tool must be the same shape of the inlet carburettor.
Vérifier que l'outil doit avoir la même forme que l'admission du carburateur.

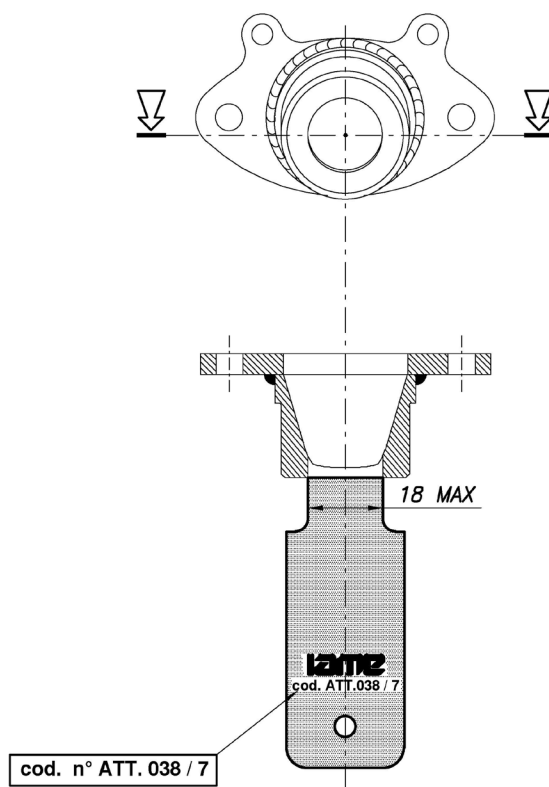

Check that the tool does not enter into the exhaust restrictor.
Vérifier que l'outil n'entre pas dans le restricteur d'échappement



CARBURETTOR / CARBURATEUR
Tillotson HW-31A

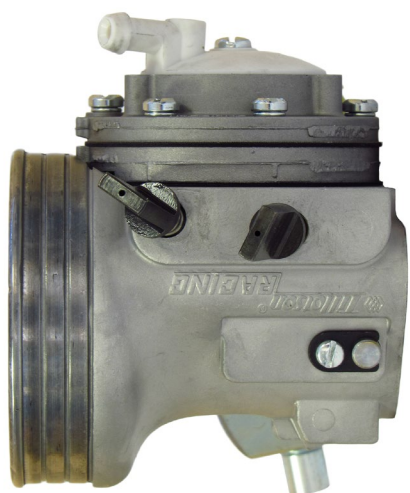

PHOTO OF ADJUSTING SIDE
 PHOTO CÔTÉ RÉGLAGE

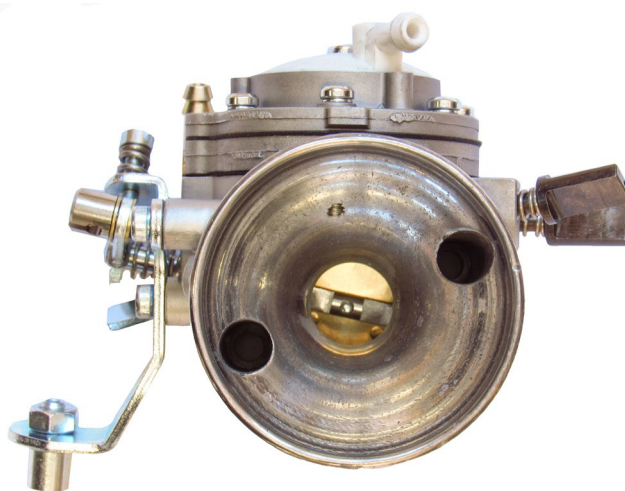
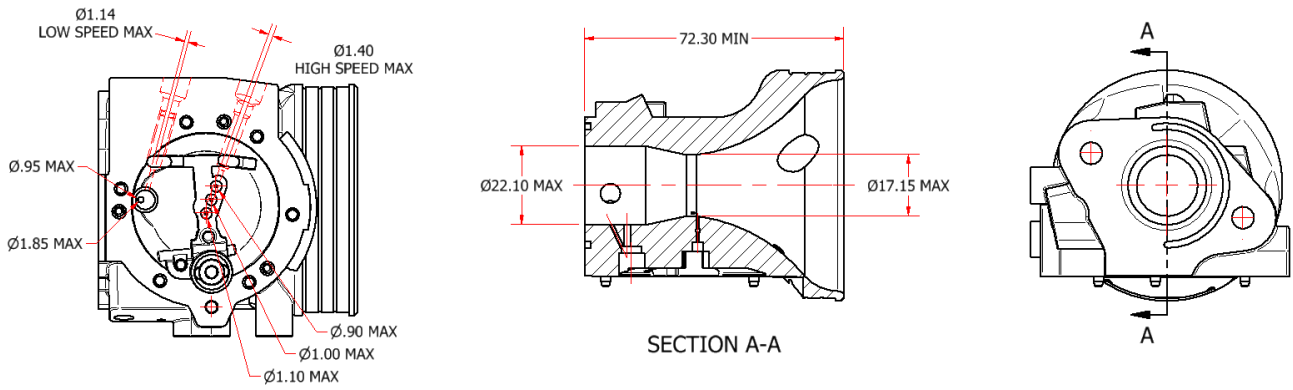

PHOTO OF INLET SIDE
 PHOTO CÔTÉ ASPIRATION

Manufacturer - <i>Constructeur</i>	TILLOTSON LTD.
Make - <i>Marque</i>	TILLOTSON
Model - <i>Modèle</i>	HW-31A

SECTION VIEW – VUE DE SECTION AVEC DIMENSIONS



“IAME” MARKING – MARQUAGE “IAME”

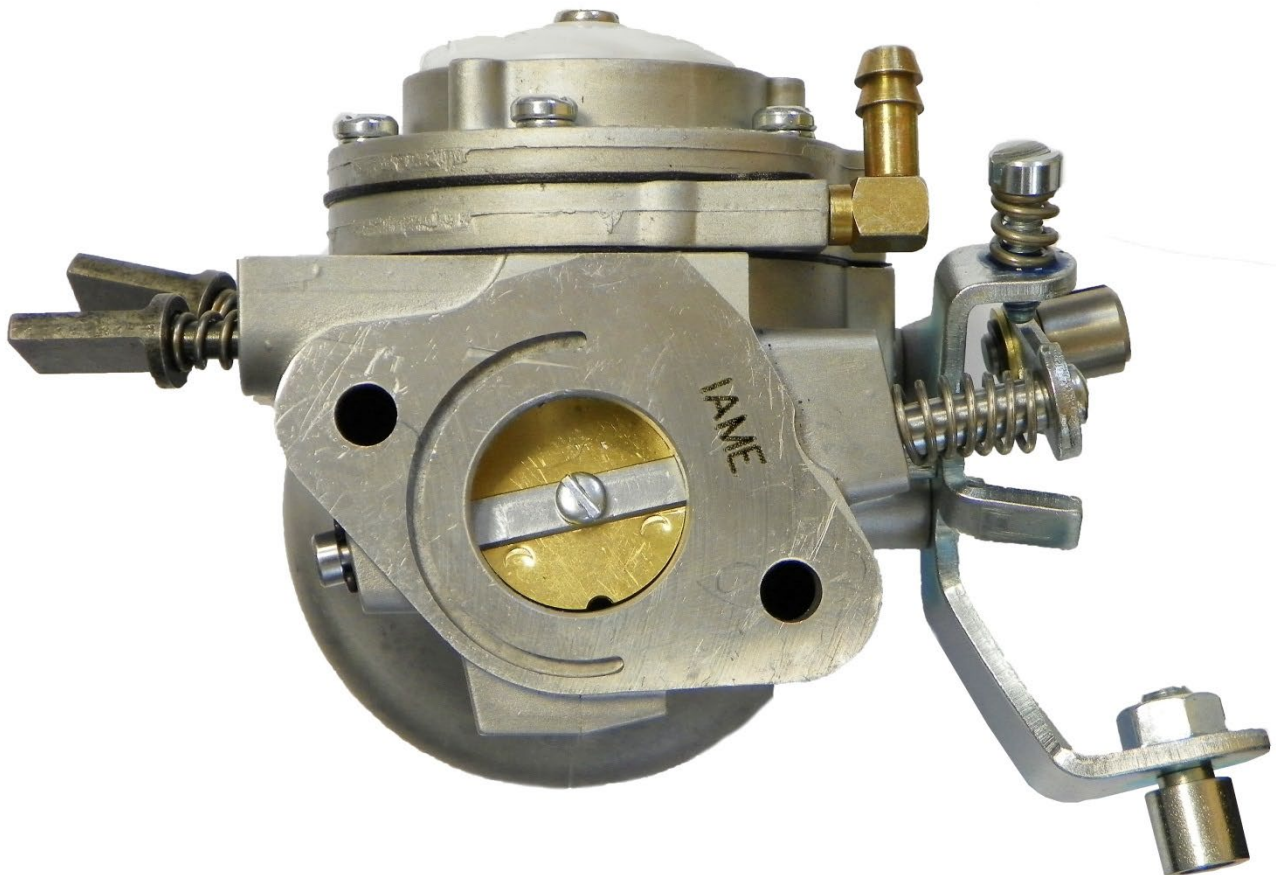

CARBURETTOR - DESCRIPTION AND SKETCH OF PARTS CARBURATEUR - DESCRIPTION ET DESSIN DES PIÈCES

HW-31A

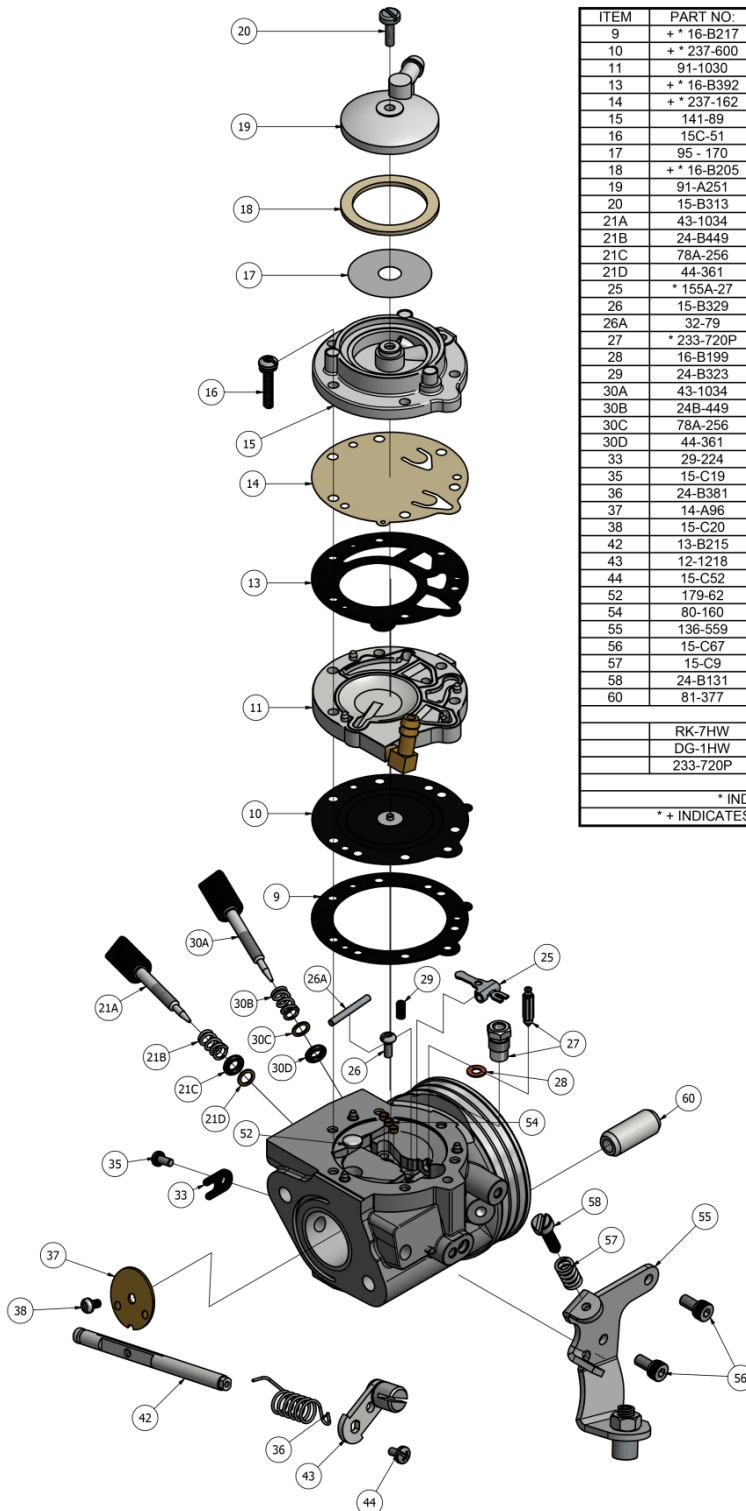

ITEM	PART NO.	DESCRIPTION	QTY
9	+ * 16-B217	DIAPHRAGM GASKET	1
10	+ * 237-600	DIAPHRAGM	1
11	91-1030	DIAPHRAGM COVER	1
13	+ * 16-B392	FUEL PUMP GASKET	1
14	+ * 237-162	FUEL PUMP DIAPHRAGM	1
15	141-89	FUEL PUMP BODY	1
16	15C-51	FUEL PUMP BODY SCREW	6
17	95 - 170	FUEL STRAINER SCREEN	1
18	+ * 16-B205	FUEL STRAINER COVER GASKET	1
19	91-A251	FUEL STRAINER COVER	1
20	15-B313	FUEL STRAINER COVER RETAINING SCREW	1
21A	43-1034	IDLE MIXTURE SCREW	1
21B	24-B449	IDLE MIXTURE SCREW SPRING	1
21C	78A-256	IDLE MIXTURE SCREW WASHER	1
21D	44-361	IDLE MIXTURE SCREW PACKING	1
25	* 155A-27	INLET CONTROL LEVER	1
26	15-B329	FULCRUM LEVER SCREW	1
26A	32-79	FULCRUM LEVER PIN	1
27	* 233-720P	INLET NEEDLE & SEAT SET	1
28	16-B199	INLET SEAT GASKET	1
29	24-B323	INLET TENSION SPRING	1
30A	43-1034	HIGH SPEED MIXTURE SCREW	1
30B	24B-449	HIGH SPEED MIXTURE SCREW SPRING	1
30C	78A-256	HIGH SPEED MIXTURE SCREW WASHER	1
30D	44-361	HIGH SPEED MIXTURE SCREW PACKING	1
33	29-224	THROTTLE SHAFT CLIP	1
35	15-C19	THROTTLE SHAFT CLIP RETAINING SCREW	1
36	24-B381	THROTTLE RETURN SPRING	1
37	14-A96	THROTTLE SHUTTER	1
38	15-C20	THROTTLE SHUTTER SCREW	1
42	13-B215	THROTTLE SHAFT	1
43	12-1218	THROTTLE LEVER ASSEMBLY	1
44	15-C52	THROTTLE LEVER RETAINING SCREW	1
52	179-62	WELCH PLUG	1
54	80-160	MAIN PLUG	3
55	136-559	CABLE BRACKET	1
56	15-C67	CABLE BRACKET RETAINING SCREW	2
57	15-C9	LIMITER SCREW	2
58	24-B131	LIMITER SPRING	2
60	81-377	CARBURETTOR MOUNTING NUT	2
RK-7HW		REPAIR KIT	
DG-1HW		DIAPHRAGM & GASKET (STANDARD)	
233-720P		INLET NEEDLE & SEAT SET	
* INDICATES CONTENTS OF REPAIR KIT			
* + INDICATES CONTENTS OF DIAPHRAGM & GASKET SET			



Clash Industrial Estate - Tralee - Ireland
www.tillotson-racing.com



PARTS OF CARBURETTOR – PIÈCES DU CARBURATEUR

REF.9 - P. N°16-B217
DIAPHRAGM GASKET
JOINT DE DIAPHRAGME

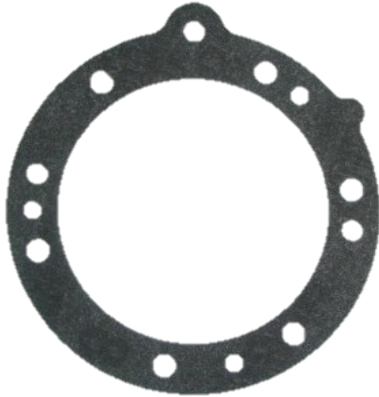

Thickness / Epaisseur = 0.5 ± 0.1 mm

REF.13 - P. N° 16-B392
PUMP DIAPHRAGM GASKET
JOINT DE POMPE A ESSENCE



Thickness / Epaisseur = 0.8 ± 0.1 mm

REF.10 - P. N°237-600
DIAPHRAGM
DIAPHRAGME ASSEMBLE



Thickness / Epaisseur = 0.13 ± 0.07 mm

REF.14 - P. N°237-162
PUMP DIAPHRAGM
MEMBRANE DE POMPE A ESSENCE



Thickness / Epaisseur = 0.10 ± 0.063 mm

REF.11 - P. N° 91-1031
DIAPHRAGM COVER
COUVERCLE DE DIAPHRAGME





Thickness / Epaisseur = 6.75 ± 0.15 mm

REF.15 - P. N° 141-89
PUMP COVER
CORPS DE POMPE A ESSENCE

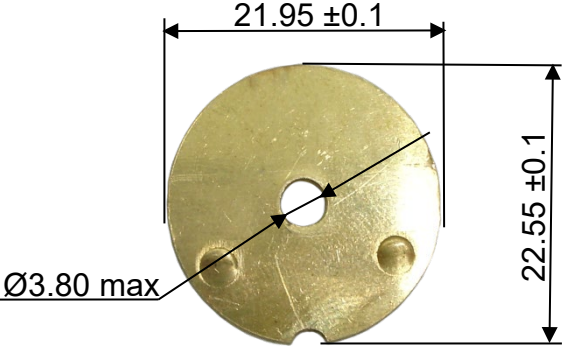
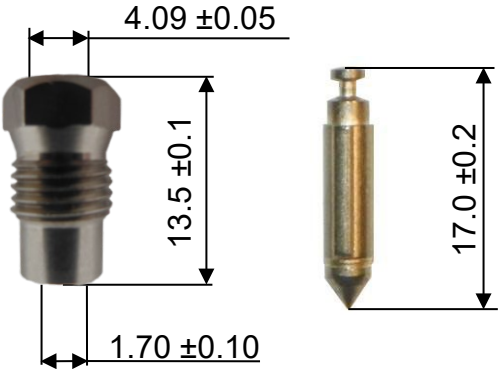
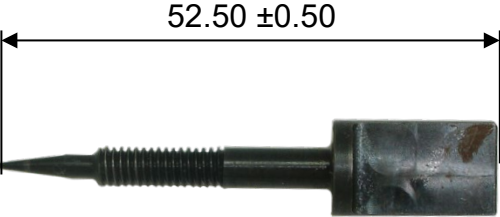
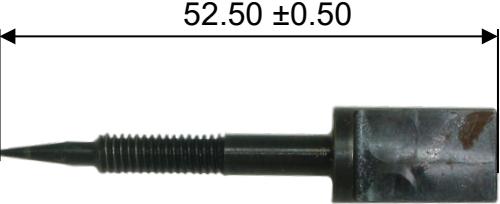

Thickness / Epaisseur = 12.5 ± 0.15 mm

<p>REF.37 - P. N° 14-A96 THROTTLE SHUTTER PAPILLON</p>  <p>Thickness / <i>Epaisseur</i> = 0.81 ± 0.1 mm</p>	<p>REF.27 - P. N° 233-720P SEAT + NEEDLE SIEGE + POINTEAU</p> 
<p>REF.21A - P. N° 43-1034 NEEDLE LOW SPEED VIS DE RAGLAGE BAS-REGIME</p> 	<p>REF.30A - P. N° 43-1034 NEEDLE HIGH SPEED VIS DE RAGLAGE HAUT-REGIME</p> 
<p>ALTERNATIVE NEEDLE FUEL POINTEAU ALTERNATIVE</p>	<p>HOLE FOR CARBURETTOR SEALING TROU POUR LE PLOMBAGE</p>
<p>REF.27 - P. N° 233-720P</p> 	<p>The carburettor can have this hole for sealing. <i>Le carburateur peut avoir ce trou pour le plombage</i></p>  <p>Ø3 HOLE / TROU</p>